

FUTURE SERVICES

future-services.net

 **PICCINI**





DUMPER

1000

FR



PICCINI



PICCINI

DUMPER

1000 FR



officine
PICCINI®

DUMPER

1000 FR

Informazioni tecniche
Technical information
Informations techniques
Informaciones técnicas



MOTORE - ENGINE - MOTEUR - MOTOR

Tipo - Type - Type - Tipo

Bicilindrico
Two-cylinder
Deux cylindres
Dos cilindros

Potenza - Power - Puissance - Potencia

HP 20 (Kw 14,7)

TRASMISSIONE - TRANSMISSION - TRANSMISSION - TRANSMISIÓN

Meccanica - Mechanical - Mécanique - Mecánica

Ruote motrici - Wheel drive - Roues motrices - Ruedas de tracción

4/4

Nr. marce (avanti / retro) - Speeds (forward / rear) - Vitesses (avant / arrière) - Velocidades (adelante / atrás)

4/4

STERZATURA - STEERING - BRAQUAGE - DIRECCIÓN

Ruote sterzanti - Steering wheels - Roues directrices - Ruedas de dirección

4/4

Tipo di sterzata - Type of steering - Type de braquage - Tipo de dirección

Idroguida
Hydraulic
Assisté
Asistida

VELOCITÀ - SPEED - VITESSE - VELOCIDAD

20 Km/h

FRENI - BRAKES - FREINS - FRENOS

Freni di servizio - Service brakes - Freins de service - Frenos de servicio

4 a disco
4 disk
4 à disques
4 a disco

Freno di stazionamento - Parking brake - Freins de stationnement - Freno de mano

A disco su trasmissione
Disk on transmission
à disque sur transmission
Disco a la transmisión

CAPACITA BENNA - BUCKET CAPACITY - CAPACITE CUVE - CAPACIDAD CUBA

A colmo - Heaped - En dôme - A colmo

1300 Lt.

In acqua - Water - En eau - En agua

1000 Lt.

Portata max. - Max. Load capacity - Capacité de charge maxi. - Capacidad de carga máxima

Kg. 2000

Portata max. con pala - Max. Load capacity with bucket - Capacité de charge maxi. avec benne auto chargeuse - Capacidad de carga máxima con cuchara auto-cargable

Kg. 1800

SERBATOI - TANKS - RESÉRVOIRS - TANQUE

gasolio - fuel - gasoil - nafta

7,0 Lt.

Olio idraulico - Hydraulic oil - Huile hydraulique - Aceite hidráulico

-

IMPIANTO ELETTRICO - ELECTRIC SYSTEM - INSTALLATION ÉLECTRIQUE - INSTALACIÓN ELÉCTRICA

12V

Pneumatici - Tyres - Pneus - Neumáticos

7.50/16

PESO A VUOTO - EMPTY WEIGHT - POIDS A VIDE - PESO EN VACÍO

Kg. 1175

RAGGIO DI STERZATA INTERNO / ESTERNO - STEERING RADIUS INTERNAL / EXTERNAL - RAYON DE VIRAGE INTÉRIEUR / EXTÉRIEUR - RADIO DE VUELTA INTERIOR / EXTERIOR

3,46/4,76



S.S. Trasimeno Ovest 161/c
06132 Perugia -Italy
Tel. +39 075 51801 - Fax +39 075 5179166
Web Site: www.officinepiccini.it
E-Mail: info@officinepiccini.it

Vendite Italia 075 5180239
Assistenza 075 5180221
Export Sales +39 075 5180240
Service +39 075 5180221

DUMPER

1000 FR

Informazioni tecniche
Technical information
Informations techniques
Informaciones técnicas



Freni a disco sulle 4 ruote
Disk brakes on 4 wheels
Freins à disque sur les 4 roues
Frenos a disco a las 4 ruedas



4 ruote motrici e sterzanti
4 drive and steering wheels
4 roues motrices et de direction
Tracción y dirección a las 4 ruedas



Freno di stanziamento sulla trasmissione
Parking brake on transmission
Frein de stationnement sur la transmission
Freno de mano a la transmisión



Telaio sovradimensionato
Over-sized chassis
Châssis surdimensionné
Chasis sobre-dimensionado



Frizione parastrappi
Spring drive clutch
Embrayage à joint flexible
Embrague amortiguador

Idroguida e servofreno
Power assisted steering and brakes
Freins et braquage assistés hydrauliquement
Frenos y dirección asistidos hidráulicamente



Scarico a 90°
90° tipping
Déchargement à 90°
Descarga a 90°

Vasca in acciaio di alto spessore
Heavy-duty steel bucket
Cuve en acier de grande épaisseur
Cuba en acero de alto espesor



S.S. Trasimeno Ovest 161/c
06132 Perugia - Italy
Tel. +39 075 51801 - Fax +39 075 5179166
Web Site: www.officinepiccini.it
E-Mail: info@officinepiccini.it

Vendite Italia
Assistenza
Export Sales
Service

075 5180239
075 5180221
+39 075 5180240
+39 075 5180221

DUMPER

1000 FR

Informazioni tecniche
Technical information
Informations techniques
Informaciones técnicas



DIMENSIONI – DIMENSIONS – DIMENSIONS - DIMENSIONES

A	400
B	1550
C	800
D	2750
E	410
F	1140
G	3890
H	1280
I	300
L	1900
M	1300
N	1500
O	-
P	1400
Q	2150
R	1200

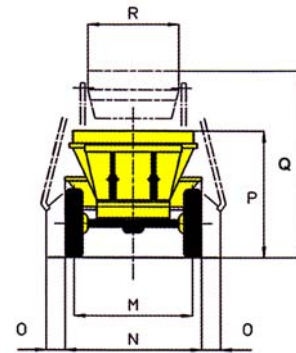
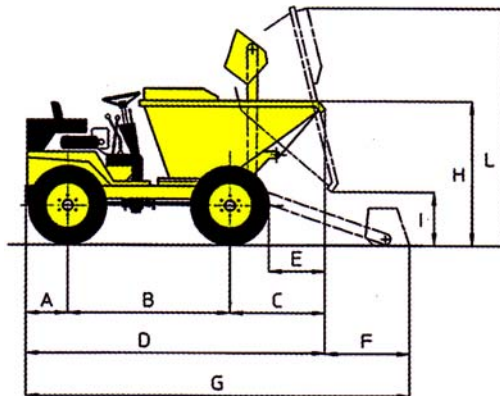

ACCESSORI – ACCESSORIES – ACCESSOIRES - ACCESORIOS

Trasmissione 4 ruote motrici di serie
4 wheel - drive standard
4 roues motrices de série
4 ruedas motrices de serie

Quattro ruote sterzanti
4 steering wheels
4 roues directrices
4 ruedas de dirección

Lampeggiante magnetico
Yellow Blinking light
Clignotant à lumière magnétique
Bombilla de aviso

Impianto luci per circolazione su strada
Road use Lighting System
Installation d'éclairage pour circulation sur route
Instalación de luces para circulación vial

Omologazione stradale
Road homologation for road use
Homologation pour circulation sur route
Homologación para circulación vial

Tettuccio di protezione operatore
Operator Protection Roof
Auvent de protection opérateur
Tejadillo de protección

Roll bar
Roll bar
Roll bar
Roll bar

Pala auto caricante
Self loading shovel
Godet auto chargeur
Cuchara auto cargable

Scarico trilaterale
Trilateral discharging
Déversement trilatéral
Descara trilateral

Telaio articolato
Articulated chassis
Châssis articulé
Chasis articulado

Trasmissione idrostatica
Hydrostatic transmission
Transmission hydrostatique
Transmisión hidrostática

 **officine PICCINI®**
S.S. Trasimeno Ovest 161/c
06132 Perugia - Italy
Tel. +39 075 51801 - Fax +39 075 5179166
Web Site: www.officinepiccini.it
E-Mail: info@officinepiccini.it



Frontale con pala auto-caricante
Front tipping with self-loading shovel
Déchargement frontale avec benne auto chargeuse
Descarga frontal con cuchara



Trilaterale con pala auto-ricaricante
Trilateral tipping with self-loading shovel
Déchargement trilatéral avec benne auto chargeuse
Descarga trilateral con cuchara



Dumper 750 / 1000 a scarico frontale
Front tipping Dumper 750 / 1000
Dumper 750 / 1000 à déchargement frontale
Dumper 750 / 1000 descarga frontal



Roll-bar



Tettuccio di protezione
Protection roof
Toit de protection
Tejadillo de protección



Vendite Italia 075 5180239
Assistenza 075 5180221
Export Sales +39 075 5180240
Service +39 075 5180221