



## Gator High-Performance Series | Utility Vehicles



JOHN DEERE

### Gator HPX 4x4 Diesel

#### Engine and Electrical

Type	3-cylinder, 4-cycle OHV diesel
Displacement	854 cc
Maximum Torque	45 Nm @ 2500 rpm (33 ft-lb)
Ignition Type	IDI diesel
Lubrication	Full pressure
Cooling System	Liquid
Air Cleaner	Dry replaceable single-element w/remote intake
Muffler	Spark-arresting
Battery	480 CCA
Alternator	40 amp @ 3200 rpm – regulated
Headlights	Two 37.5 watt halogen

#### Fuel Capacity

20 ltr

#### Transmission

Type	Continuously variable transmission (CVT)
	Fully enclosed clutch
4WD	Operator selectable
	On-Demand "True" 4WD
Traction Assist	Standard

#### Ground Speed

High Range	0 – 40 km/h (0 – 25 mph)
Low Range	0 – 19 km/h (0 – 12 mph)
Transaxle	Two-speed, oil bath
Gear Selection	Forward (high-low), neutral, reverse
Brakes	Front/rear hydraulic disk
Park Brake	Rear hydro-mechanical disk

#### Suspension and Steering

Suspension, Front	MacPherson strut, single A-arm
Suspension, Rear	Coil over shock
Ground Clearance:	
Under Transaxle	153 mm (6 in)
Under Foot Platform	330 mm (13 in)
Steering	Rack and pinion

#### Rollover Protective Structure

SAE ROPS certified Deluxe Canopy

#### Dimensions

Length (with bumper)	2870 mm (113 in)
Width	1506 mm (59.3 in)
Front-Tread Centres	1257.3 mm (49.5 in)
Rear-Tread Centres	1219.3 mm (48 in)
Height (overall with OPS)	1850 mm (72.9 in)
Wheelbase	1910 mm (75.2 in)
Weight (including fuel/fluids)	757 kg (1.669 lb)
Turn Clearance Circle	6.7 m (22 ft)
Seating Capacity, Type	2, Professional high-back
Towing/Payload Capacity	590 kg (1.300 lb)

#### Cargo Box

Load Height	787 mm
Dimensions	1116mm L x 1244mm W x 229mm D)
Volume	0.32 m <sup>3</sup> (11.2 cu.ft)
Max Box Weight	409 kg (900 lb)

#### Front Tyres

All types = 24x9.50-10 / 4-ply

#### Rear Tyres

All Purpose HPAP = 24x10.5-10 (4-ply)

All Purpose HPAT = 24x12-10 (4-ply)

Turf/hard-surface = 24x12-10 (4-ply)

All Purpose HPAP

Standard Tread Type

- High torque Yanmar 20 hp (854 cc) diesel engine and durable hydroformed steel frame provide plenty of power and strength for heavy duty haulage applications.
- On-demand true 4WD, for the ultimate traction, on all HPX 4X4 models. (Engage when needed, system automatically releases when traction improves.)
- The most stable vehicles in their class with the lowest centre of gravity, low ground pressure and a good power to weight ratio.
- Built for long life with industry-exclusive hydroformed steel frames
- Impressive 409 kg hauling capacity with rugged dumpable cargo box and a low load height
- Can carry up to 590 kg, including two adults, at speeds of up to 40 km/h; towing capacity is also 590 kg.
- Standard integrated certified ROPS canopy can be fitted up to an optional deluxe full glass cab if required.
- Standard features also include comfortable high back seats and a 12V DC outlet.

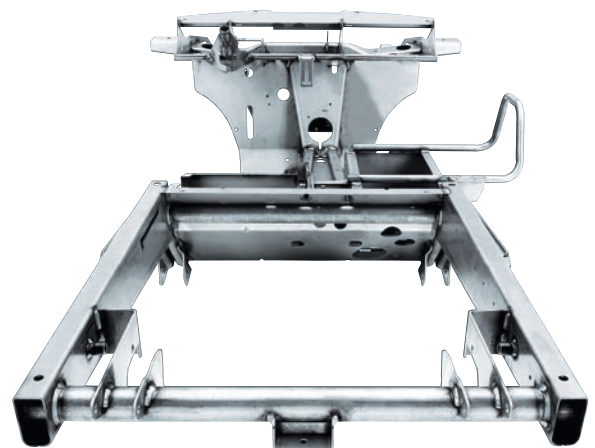

## 6x4 TRAIL GATOR UTILITY VEHICLE - DIESEL



### Add Versatility with:

- Windshield
- Power lift kit
- Light and horn kit
- Rear hitch
- Bedliner
- Horn kit
- Back-up alarm kit
- 72-inch front blade
- Heavy-duty front suspension kit
- Special Applications Equipment**
- Gun boots
- Full camouflage seat covers and storage bags
- Dog crate
- Tool holder
- Electric three-point hitch
- 80-gal (303L) sprayer
- Speedometer
- Pintle hitch
- Seeder/Spreader
- Tailgate ramp
- Medical rescue kit
- Fire camen (6x4 only)

## Features

The John Deere 6x4 Diesel Trail Gator Utility Vehicle is designed to give sportsmen a powerful and comfortable means of transportation to and from the field.

The 6x4 Trail Gator Utility Vehicle has a 3 cylinder, 18-hp, liquid-cooled Yanmar diesel engine which gives the vehicle more high-end torque and increased engine life.

Two front wheels, low center of gravity, relocated drivetrain, and maximum ground speed of 18 mph provides stability and safer operation.

Other features include offset operator's seat, passenger grab handle, and three turns lock-to-lock steering

It features side-by-side seating with raised seat edges and hip restraints. Professional high-back seats add comfort and support.

Large capacity boxes provide plenty of room for hauling. The Diesel Trail Gator Utility Vehicle has a 1,000-pound box capacity with a self-locking box latch (without hydraulic dump) that holds box in "up" and "down" positions.

Automotive-type controls with rack-and-pinion system for smooth responsive operation. Fully independent, single A-arm suspension means better off-road control.

Transaxle has great torque capacity for handling loads. Internal wet-disk brakes (an industry exclusive) on both output shafts give positive

stopping and long life.

Heavy-duty clutch design gives quiet operation and smooth shifting when operating on hills or hauling heavy loads. Clutch system is tuned to provide downhill braking for reduced brake wear.

You get the best flotation in the industry. Due to low pressure flotation-type tires, ground pressure is very low and does not change much when the vehicle is loaded. This allows sportsmen to reach their remote destinations without harming the natural landscape. Two tire options are available for the Trail Gator. HDAP (Heavy-Duty All Purpose) tires offer greater puncture and wear resistance with deep-lug design. The run-flat tires will operate up to 50 miles at a very low or zero inflation pressure without tire collapsing.

Lower engine RPM and design refinements make the Trail Gators quiet in the field. Heavy-duty design features are arc-welded. Unibody construction for maximum strength and tolerance control. Bolt-on, cast aluminum rear axle housings and large, one-piece forged axles provide an extremely strong supporting structure.

Trail Gators are painted olive drab green with black seats and wheels. These features allow these utility vehicles to blend in with the surroundings. Heavy-duty all purpose tires, front bumper and front brush guard are standard equipment on the trail models.

### ADDITIONAL FEATURES:

- Full-pressure engine lubrication
- Glo-plug indicator light
- Air-restriction indicator
- Neutral-start switch
- Park-brake indicator light
- Easy-to-use parking brake
- Glove box
- Removable tailgate
- Hourmeter

# Specifications

## 6x4 Diesel Trail Gator

### engine:

Make	Yanmar
Type	4-cycle diesel
Cylinders	3
Valving	Overhead valves
Displacement	40.2 cu. in. (658 cc)
Horsepower (SAE J1940)	18
Maximum torque	28.9 lb-ft @ 2,700 rpm
Ignition	IDI diesel
Lubrication	Full-pressure
Oil filter	Replaceable (standard)
Rpm, idle (no load)	1,000
Rpm, fast (no load)	3,550
Cooling system	Liquid
Air cleaner	Dry replaceable dual-element w/remote intake
Muffler	Spark arresting option
Battery	32 amp/hr; 340 cold cranking amps
Alternator	40-amp, regulated
Headlights	Two 37.5-watt halogens

### Fuel System:

Capacity	5.3 U.S. gal (20.0 L)
Consumption at half load and average speed	0.25 U.S. gal./hr. (0.961 L/h)

### machine:

#### Transmission:

Type	Continuously Variable Transmission (CVT)
Differential lock	Standard, hand operated
Drive chain	No. 50 industrial roller
Ground speed	0-18 mph (0-29 km/h)
Transaxle	Fully enclosed; oil bath
Gear selection	Forward, neutral, reverse
Overall reduction ratio:	
Low	70.8:1
High	14.3:1
Brakes	Wet disk in transaxle

#### Steering:

Ground pressure (maximum):	
With 200-Lb. operator only	6.9 psi (.49 kg/cm <sup>2</sup> )
Fully loaded vehicle	7.3 psi (.51 kg/cm <sup>2</sup> )

#### Dimensions:

Length (without bumper)	104.9 in. (2665 mm)
Length (with bumper)	106.0 in. (2930 mm)
Width	60.0 in. (1525 mm)
Front tread centers	50.0 in. (1270 mm)
Rear tread centers	48.0 in. (1220 mm)
Height (overall)	43.6 in. (1107 mm)
Wheelbase	79.0 in. (2006 mm) front/rear
Weight (incl. fuel/fluids)	1,057 Lb. (479.4 kg)
Ground clearance:	
Under transaxle	6.7 in. (170 mm)
Under foot platform	8.5 in. (215 mm)
Payload capacity	1,400 Lb. (636 kg)
Towing capacity	1,400 Lb. (636 kg)
Seating capacity	2
Seat type	Professional high-back
Turn clearance circle	24.8 ft. (7.6 m)

#### Tires:

Front	(2) 22.5x10.00-8, 2-ply hi-flotation
Rear	(4) 25x12.00-9, 2-ply hi-flotation
Tread types available	Heavy-Duty All Purpose and Run-flat

#### Cargo Box:

Material	16 gauge steel
Capacity (volume)	11.2 cu. ft. (0.32 m <sup>3</sup> )
Weight (level terrain)	1,000 Lb. (454 kg)
Width (inside)	49 in. (1245 mm)
Length	44 in. (1118 mm)
Depth	9 in. (229 mm)
Dump	Manual (power lift available)
Tailgate	Removable; hinged at bottom

\*Includes 200-Lb. operator, 200-Lb. passenger, and maximum box capacity

