



980H

Wheel Loader



CAT[®]

Cat[®] C15 Diesel Engine with ACERT™ Technology

Gross Power (SAE J1995) 293 kW/398 hp

Net Power (ISO 9249) at 1800 rpm 260 kW/354 hp

Bucket Capacity 4.5 to 6.1 m³

Operating Weight 31 000 to 33 300 kg

980H Wheel Loader

H-Series Wheel Loaders – The New Standard for Midsize Loaders

Reliability and Durability

- Proven Components and Technology
- ACERT Technology Maintains Performance, Efficiency and Durability while Meeting Emissions Regulations
- Heavy Duty Components Stand Up to All Operating Conditions
- Strong, Solid Structures Built to Last

pg. 4

Productivity and Versatility

- Constant Net Horsepower through the Operating Range
- Aggregate Autodig Automates the Loading Process
- Large Variety of Cat® Work Tools

pg. 6

Operator Comfort

- Easy Entry and Exit
- Excellent Visibility
- Comfortable Environment with Controlled Vibration
- Quiet, Comfortable Cab
- Reduced Operator Effort

pg. 8

Performance you can feel with the capability to work in the most demanding applications. Unmatched operator comfort and efficiency in a world class cab. Revolutionary electronics for low-effort operation. Increased productivity with lower owning and operating costs.

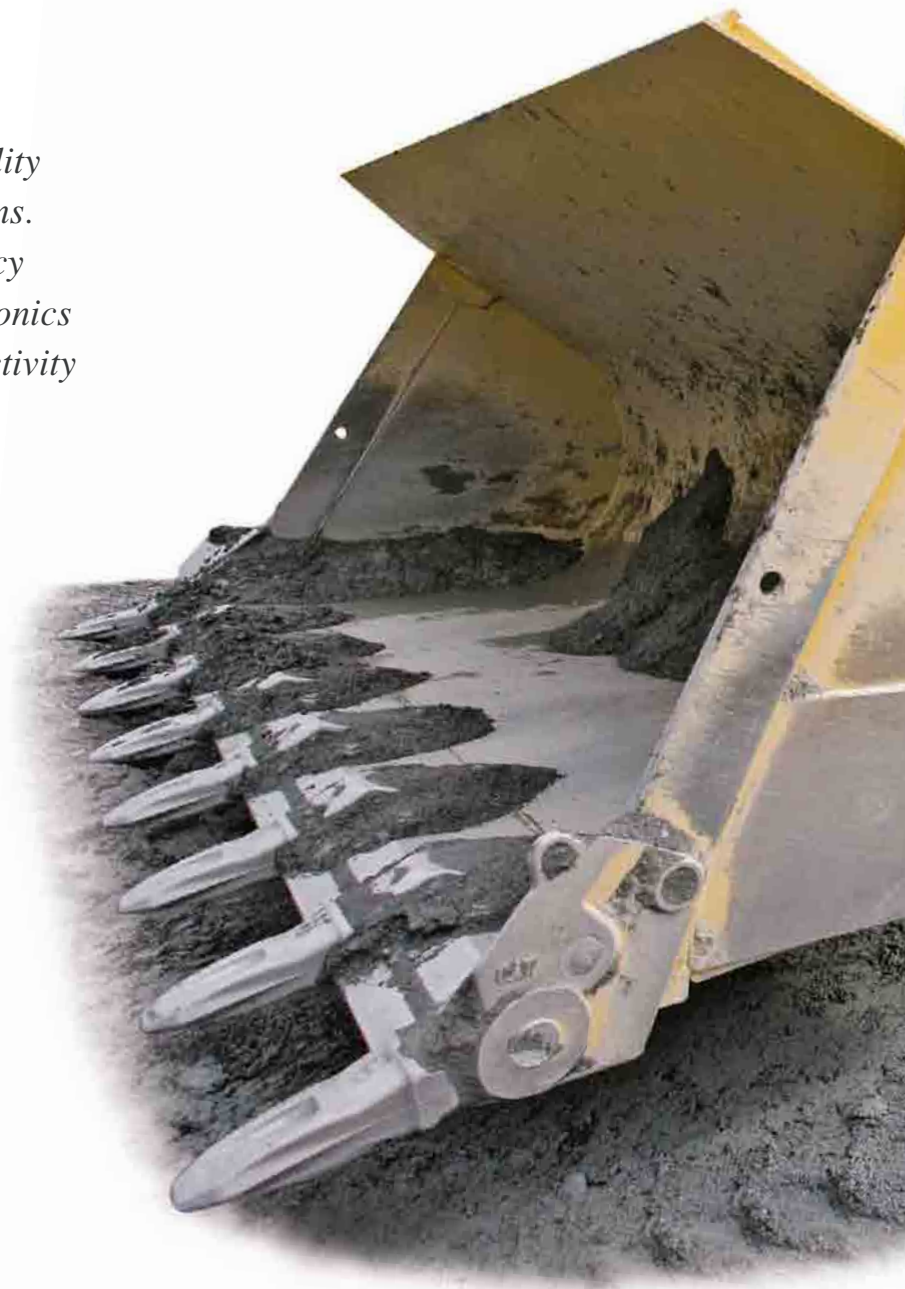

Serviceability

- Exceptional Access to Service Points
- Monitoring Systems and Dealer Support
Reduce Unexpected Downtime

pg. 10

Owning and Operating Cost

- Proven Fuel Efficiency
- Superior Maintenance
- Electronic Systems Monitor Product Health
and Performance
- Complete Dealer Support

pg. 12



Reliability and Durability

The Cat 980H – Built Strong and Tough – Tested And Proven – Ready To Work

- Proven components and technology
- Electronic systems monitor vital machine components
- ACERT Technology maintains engine performance, efficiency and durability while reducing emissions
- Heavy duty components withstand all operating conditions

Proven Reliability. The 980H features many of the components designed and proven in previous 980 models – all contribute to the reliability of the 980H:

- Frames
- Axles
- Planetary powershift transmission
- IBS – Integrated Breaking System
- Separated cooling system
- Cab

Engine. EU Stage IIIA compliant C15 engine with ACERT Technology combines proven systems with innovative new technologies to precisely deliver fuel to the combustion chamber. It maintains engine performance, efficiency and durability while dramatically reducing emissions.

The Cat C15 is a 15.2 L displacement, 6-cylinder, electronically governed engine. Electronic fuel injection is provided through the well-proven Caterpillar mechanically actuated, electronically controlled unit injection system. A wastegate turbocharger, equipped with a titanium wheel for improved durability, combined with air-to-air aftercooling (ATAAC) provides consistent high horsepower with increased altitude capability.

Electronic Controller. The engine is governed by an electronic control module designated the A4:E4V2. The controller continually adjusts engine output based on load demand using a series of sensors located on the machine and engine.



Mechanically Actuated Electronic Unit Injectors (MEUI). The MEUI system has been at work in Cat engines across the product line with a proven track record of consistent, durable, reliable performance.

Engine Block and Pistons. The gray cast iron engine block is made of the same material as the cylinder heads. Wall diameters are thicker than in previous designs while adjustments have been made to reduce sound levels and increase rigidity. One-piece all-steel pistons are housed within a wet, replaceable cast iron cylinder liner constructed of high-strength, heat-treated castings. Steel-forged connecting rods are larger in diameter.

Powershift Transmission. The 980H continues to use heavy-duty powershift transmission technology proven on previous models and currently used up through the largest wheel loader built by Caterpillar – the 994F. The planetary powershift transmission features heavy-duty components to handle the toughest applications. Built-in electronic controls enhance productivity and durability.

Caterpillar Designed Components.

Components used to build Cat Wheel Loaders are designed and manufactured to Caterpillar quality standards to ensure maximum performance even in extreme operating conditions.

Engine electronic control module and sensors are completely sealed against moisture and dust. Deutsch connectors and electrical wire braiding ensure that electrical connections resist corrosion and premature wear.

Hoses are engineered and manufactured for high resistance to abrasion, excellent flexibility and easy installation and replacement.

Caterpillar hose couplings use o-ring face seals to provide positive sealing for durable leak-free connections.

Heavy duty components reduce the risk of leaks, corrosion and premature wear increasing uptime and helping to protect the environment.



Caterpillar Monitoring System.

The 980H is equipped with the Cat Monitoring System (CMS) that keeps watch over the health of your loader. CMS monitors critical engine system functions and will derate the engine to protect itself from damage if needed. Depending on which of the following six critical conditions arise, the CMS monitor or front panel will display warning lights and sound audible alarms.

- High coolant temperature
- High air inlet temperature
- Low engine oil pressure
- High fuel pressure
- Low fuel pressure
- Engine over-speed

Axles. The 980H axles are designed by Caterpillar for durability in all operating conditions. The front axle is rigidly mounted to the frame to support the weight of the wheel loader and withstand internal torque loads as well as external forces encountered throughout operation. The rear axle is designed to allow $\pm 13^\circ$ oscillation. All four wheels remain on the ground over uneven terrain providing excellent stability and traction.

Integrated Braking System (IBS).

The Cat exclusive Integrated Braking System reduces axle oil temperatures and improves transmission neutralizer smoothness. IBS has a direct impact on durability of the axles and brakes especially in applications involving long distances and/or heavy braking.

- A** Downshift logic only
- B** Brake application initiated
- C** Self-adjusting transmission neutralization

Structures. The articulated frame design of the 980H features a durable box-section engine end frame and rigid four-plate loader tower that is robotically welded. Robotic welding creates frame joints with deep plate penetration welds and excellent fusion for maximum strength and durability.

Rear Frame. A full box-section engine end frame with hitch plates at the front end provides a strong, rigid structure that resists twisting and impact loads. The result is an extremely solid mounting platform for the engine, transmission, axle, ROPS and other accessories.

Spread Hitch. The distance between the upper and lower hitch plates is important for machine performance and component life. The Cat spread hitch design provides excellent load distribution and bearing life. Both the upper and lower hitch pins pivot on double tapered roller bearings – improving durability by distributing both vertical and horizontal loads over a larger surface area. The wide opening also provides excellent service access.

Front Frame. The non-engine end frame provides a solid mounting base for the front axle, lift arms, lift cylinders and tilt cylinders. The fabricated, four-plate loader tower absorbs the forces associated with loading, twisting and penetration.

Linkage. The 980H linkage is a dual-tilt Z-bar design. Z-bar linkage generates excellent breakout force and good rack back angle for better bucket loading and load retention. The Z bars' light weight compared to other linkage designs allows for more payload capacity. Lift arms are solid steel, providing superior strength with an excellent front end viewing area. The proven design offers excellent dump clearance and reach for exceptional matching to on- and off-highway trucks. Rotary sensors, for the tilt lever and lift circuit allow the operator to electronically set detent positions from the cab.

Productivity and Versatility

Work Smart And Move More



- Electro-hydraulic controls reduce cycle times
- Consistent horsepower regardless of conditions
- A variety of buckets and work tools for many applications

Electro-hydraulic Implement Controls.

Finger Tip electro-hydraulic implement controls on the 980H provide the operator with responsive, smooth and precise control of bucket and lift arms.

Single Lever Control. The optional single lever (joystick) hydraulic control is retained with the 980H. It is a dual axis control, with fore and aft motion controlling the lift function.

An additional feature of the hydraulic system is the Full Rack Angle Control (FRAC).

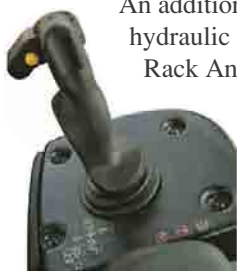

This feature automatically adjusts the bucket angle as it is raised to maintain a constant angle.



Automatic Kick-Outs. The standard programmable automatic kick-outs provide flexibility and productivity for precise load and dump target heights. Tilt, lift and return-to-dig kickouts are set by positioning the bucket or work tool and setting a rocker switch in the cab.

Constant Net Horsepower. On many competitive machines, gross horsepower is constant, meaning that net engine power available for actual work will vary based on demands made from parasitic sources, such as air conditioning or cooling fans. The Cat C15 engine is electronically configured to provide constant net horsepower at full parasitic load enhancing productivity and improving fuel efficiency.

Separated Cooling System. Many competitive loaders use cooling systems that pull air in from the sides, through the engine compartment and exhaust it out the rear of the machine. The 980H cooling system is isolated from the engine compartment by a non-metallic shield. The hydraulically driven, variable speed fan draws in clean air from the rear of the machine and exhausts it out the sides and top of the hood. The end results are optimal cooling efficiency, increased fuel efficiency, less radiator plugging and reduced operator sound levels.



Planetary Power Shift Transmission.

Increases number of cycles per hour. The electronic planetary power shift transmission with automatic shift capability is designed, developed and built by Caterpillar. The electronically controlled power shift transmission allows full power, very responsive directional changes that have a direct impact on machine cycle times and productivity. The operator can choose between manual or autoshift modes.



Variable Shift Control.

Match transmission shifting patterns to machine application requirements. Variable Shift Control (VSC) improves shift quality and fuel efficiency in certain applications by allowing the transmission to upshift at lower engine RPMs.

Ride Control. The optional Ride Control System improves ride, performance and load retention when traveling over rough terrain. Operators gain confidence moving at higher speeds in load and carry operations decreasing cycle times and increasing productivity.

Aggregate Autodig. Well-received by both experienced and novice operators, the optional Aggregate Autodig fully automates the loading process.

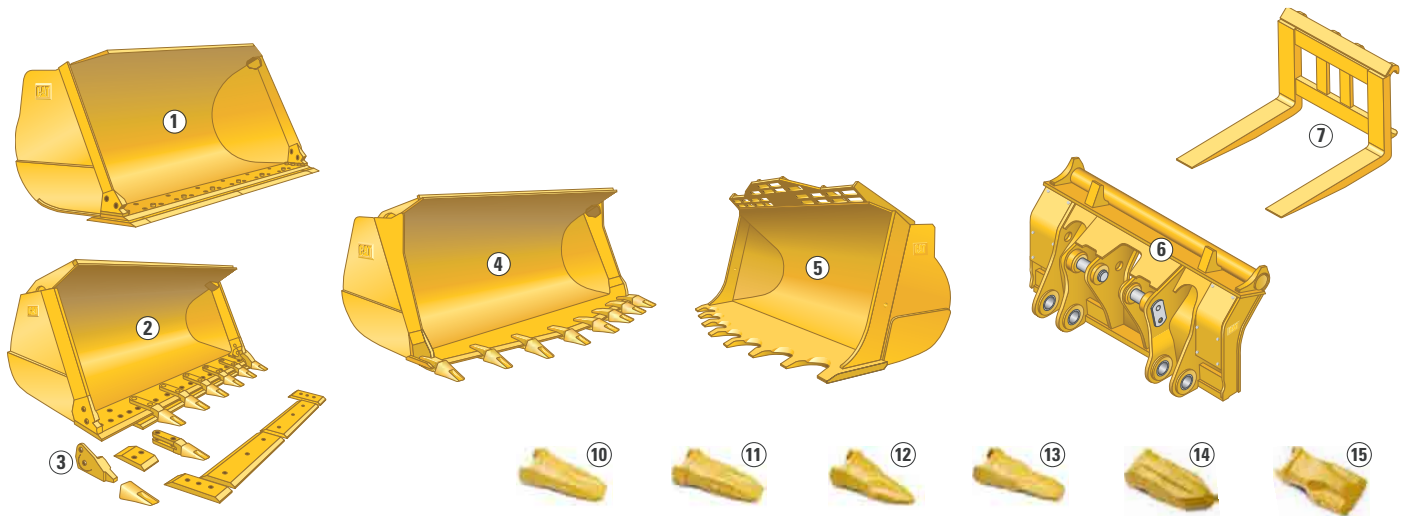

1 Universal Buckets. This is a complete line of flat floor buckets, designed for loose material (re)handling. Equipped with various GET (Ground Engaging Tools), they provide easier pile penetration, better fill factors and faster loading cycles; they are offered in a wide range of capacities. All buckets feature bottom and side wear plates for greater durability. Universal buckets are for use with both standard and high lift arm configuration.

2 General Excavation Buckets. Built to handle the toughest conditions, these buckets are excellent for bank and excavation applications. They feature proven, shell-tine construction that resists twisting and distortion. Bucket hinges are part of the structure that extends under the bucket shell to the cutting edge, forming box sections that resist impact forces. All buckets have integral spill plates that prevent possible spillage over the linkage. Replaceable rear wear plates protect the bottom of the bucket. Bucket side plates are also reinforced in their lower portion with additional wear plates. Buckets feature Corner Guard System and can be fitted with optional bolt-on GET.

3 Corner Guard System. Allows maximum flexibility between teeth and edge systems for superior protection and performance in each application. Featured on General Excavation buckets and some Universal buckets.

4 Rock Buckets. Caterpillar rock buckets are built to tough standards. The spade-edge design provides easier penetration and makes them well suited for high-impact jobs. Optional Ground Engaging Tools include bolt-on cutting edge and weld-on two-strap adapters to be fitted with Caterpillar K Series tips, with or without standard or heavy-duty bolt-on segments.

5 Serrated V-Edge Rock Buckets. These rock buckets provide excellent penetration characteristics in low-abrasion applications. The replaceable V-edge has self-sharpening teeth and chamfers. There are no GET (pin-on or bolt-on) – like tips – installed, which tremendously reduces the chance of iron falling into the crusher. The flat bucket floor provides excellent clean-up capability. In the correct application the serrated edge bucket lowers the cost per ton for the entire machine.

6 Dedicated Quick Couplers. Allow the operator to perform a wide variety of tasks with just one machine and various work tools, providing unmatched versatility and resulting in cost efficiency. With the separate optional quick coupler circuit, actuate the quick coupler and change and operate non-hydraulic work tools from the cab. The third valve can be used to actuate hydraulic work tools, like high dump buckets.

7 Forks. Pallet forks are the ideal tools for handling a variety of materials. These forks are available in different sizes, pin-on or fitted with dedicated quick coupler hinges.

Quick Coupler Buckets. A wide range of buckets fitted with dedicated quick coupler hinges is available. Caterpillar offers you the right bucket for the right application.

High Dump Buckets. These buckets increase the dump height of the machine and make it possible to tip loose material over high barriers. Ideal for applications as various as loading stockpiled, light material into high sided trucks or hoppers in waste transfer stations or rehandling fertilizer, coal or grain. The high dump buckets are hydraulically operated and require a 3rd valve.

K Series Tip Selection. The new Caterpillar K Series™ Tooth System holds tighter, changes easier and stays sharper.

- 10** General Duty
- 11** Extra Duty
- 12** Penetration
- 13** Penetration Plus
- 14** Heavy Penetration
- 15** Heavy Abrasion

A complete range of work tools is available from your Caterpillar dealer.

Operator Comfort

Work Comfortably And Efficiently

- Comfortable operation
- Excellent visibility
- Easy entry and exit
- Controlled vibration

Operator Environment. The 980H maintains the distinction of offering the largest, most ergonomic cab in its class.

Seat. The Cat C-500 Series Comfort air suspension seat, standard in the 980H, is built strong and durable and is 6-way adjustable to accommodate all-sized operators. The cast one-piece back and seat pan prevent protrusions under the cushions. The seat features an automotive-style lumbar support for maximum comfort. The right hand armrest with integrated implement controls adjusts for comfortable, convenient operation. A heated seat option is available for additional comfort.

Vibration. By controlling normal machine vibrations, operator efficiency and productivity are improved. From the ground up, the Cat 980H is designed with many features, both standard and optional, that reduce vibration.

- The oscillating rear axle follows the contour of the ground while allowing the cab to stay steady.
- The cab is attached to the frame with iso-mounts designed to reduce shock loads from the ground.
- The articulation joint is equipped with two neutralizer valves that prevent frame-to-frame contact.
- Cylinder dampening slows the bucket as it reaches the limits of travel, preventing machine jarring.
- Ride Control is an option designed to reduce jolting and bouncing during load and carry operations.
- Electronically controlled, automatic kickouts prevent the jerking and bouncing associated with abrupt cylinder stops.
- Air suspension seat-mounted implement controls reduce vertical vibrations that come up through the cabin floor.



Command Control Steering.

This is a load-sensing system that links the steering wheel and frame angle positions to provide the proper amount of steering control. The speed the machine turns is proportional to the steering wheel position. Less than 26 N steering effort is required by the operator, regardless of conditions.

Full machine articulation is accomplished with a $\pm 70^\circ$ turn of the wheel – versus two to three 360° turns of a conventional steering wheel. The Command Control Steering wheel contains the forward/neutral/reverse switch and the upshift/downshift button – allowing the left hand to remain on the steering wheel at all times. The CCS column inclines 35° and the telescopic change is up to 100 mm.





Controls. The main control panel on the 980H is located high on the right ROPS post – keeping everything within reach of the operator while maintaining visibility to the ground. Keeping all switches and controls conveniently placed allows better operator efficiency and improved productivity, while minimizing operator fatigue.

Optional Aggregate Autodig System.

It provides smoother loading cycles and consistently full payloads without touching the controls – reducing operator fatigue.

Visibility. The 980H provides excellent visibility to both the front and rear of the machine. Distortion-free flat glass stretches to the floor of the cab for excellent visibility to the bucket. Wet-arm wipers on both front and back keep the windows clean in any condition. The cab roof has channels that direct rain off the corners of the cab keeping windows clear. An overhang on all sides protects the operator from glare.

Rear Vision Camera. An optional rear vision camera is available to clearly monitor movement behind the wheel loader.

Lighting Packages. Optional lighting packages are available for roading or low-light applications. The optional High Intensity Discharge (HID) lights provide exceptional lighting for night work. A rotating beacon is available as a safety feature.

Windshield Cleaning Package.

An optional windshield cleaning package provides additional steps and handrails to provide easy access for cleaning the front windows.



Entry and Exit. A ladder with self-cleaning steps keeps debris build-up to a minimum. The ladder is at a 5° forward incline for easy entry and exit. Platforms are wide allowing ease of movement to the front or rear of the machine. The main cab door opens a full 180° and latches in place to allow safe navigation to the rear of the machine. The right side door opens 10°, or completely for secondary exit simply by pulling a pin. A full-length ladder on the right side facilitates safe exit if needed.

Serviceability

Easy To Maintain – Easy To Service.



Engine Compartment Access.

The non-metallic hood on the 980H has been redesigned and restyled from previous models. Side and top panels are stronger due to more robust reinforcement ribs – the change in contour also adds to rigidity of the hood. Panels located behind the tires lift up and can be removed for additional access. Rooding fenders hinge from the rear and swing out allowing easier access to the engine compartment.



Cooling System. Access for clean-out and maintenance is outstanding. The perforated and corrugated grill minimizes debris build-up and swings out for easy cleaning and access to the cooling cores. The full-width air conditioning condenser and oil cooler cores swing out 45° to allow easy cleaning of the rear radiator face. Panels on either side provide access to the front face of the radiator and ATAAC cores for easy cleaning.



Autolube. Reduce time spent on daily maintenance and downtime for unplanned repairs due to inadequate greasing with the optional Caterpillar Automatic Lubrication System. Precise lubrication of pins and bushings at specific intervals decreases component wear and reduces ground contamination from excessive greasing.



The tilting hood provides excellent access to the engine compartment, and if necessary, the entire hood can be removed with the built-in lift points.

Ecology Drains. Engine, transmission and hydraulic oils can be easily drained with standard-equipment ecology drains. An axle oil ecology drain is optional.

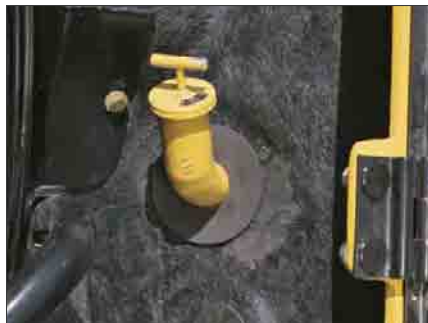

With the hood closed, quick checks of engine oil level and the coolant sight gauge can be completed through the side service doors.

Electric Priming Pump. An electric fuel priming pump located on the primary fuel filter base eliminates the need to pre-fill or manually prime filters after a change, eliminating engine contamination.

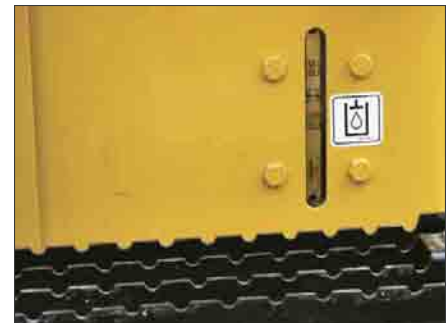

Sight Gauges. Well-protected, yet easily visible sight gauges for the transmission oil, hydraulic oil and engine coolant allow easy daily checks while reducing the risk of contaminants entering the systems.



- Convenient access to engine compartment for excellent serviceability
- Swing-out grill and cooling cores for easy cleaning
- Electronic systems to monitor product health

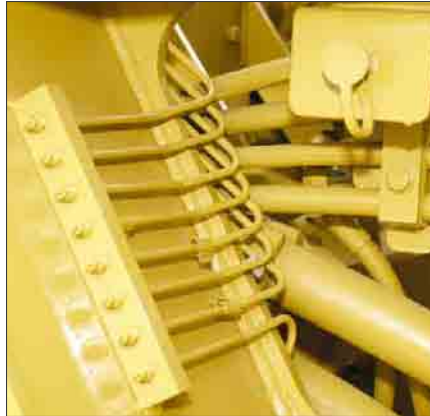

- Grouped service points and sight gauges for easy daily maintenance
- Axles are equipped with standard brake wear indicators, allowing a technician to easily determine when it is necessary to service the brakes.



Cab. The entire operator station can be removed in about 45 minutes and is easy to re-attach. Quick disconnects are used so no wires need to be cut and no refrigerant is lost.

Cab cleaning is made easy with channels on the cab floor and no threshold at the door – the floor can be swept or mopped out easily.

Windshield Cleaning Package.

An optional windshield cleaning package consists of two steps for the loader front frame, two additional handrails and a folding mirror. This package allows access to the entire front windshield for easy cleaning.

Complete Customer Support.

Cat field service technicians have the experience and tools necessary to service your loader on site. Technical experts at the dealership and Caterpillar can provide additional assistance to field service technicians as needed.

When on-site repair isn't enough, Cat dealerships are fully equipped to service your loader quickly.



- Diagnostic test ports conveniently located behind the cab
- Hydraulic oil filter change interval at 500 hours
- Transmission oil filter change interval at 1000 hours



- Maintenance-free batteries provide long life
- Ground level compartment for secure tool storage

Owning and Operating Cost

The 980H – Best Value For Your Operation



- More return for your wheel loader investment through proven Cat fuel efficiency
- Sight gauges, grouped maintenance points, easy engine access, ecology drains, maintenance-free batteries all simplify daily maintenance
- Electronic monitoring systems track product health to avoid unscheduled costly repairs
- Unsurpassed parts availability reduces downtime
- Excellent resale value provided by genuine Cat quality, outstanding dealer service and unmatched dealer support programs
- Caterpillar Financial Services and Cat dealers understand your business

ACERT Technology Fuel Economy.

Based on Caterpillar testing, the fuel economy of Cat engines with ACERT technology is 3 to 5 percent better than current competing technologies. This fuel economy is directly related to the complete combustion of fuel due to the integration between the electronic control that monitors conditions, the air management system that controls air volume and the fuel injection system that delivers just the right amount of fuel as needed.

Engine Idle Management System.

The Engine Idle Management System (EIMS) maximizes fuel efficiency and provides flexibility in managing idle speeds for specific application requirements. Four idle control speeds are available.

On-Demand Fan. Temperature levels of the engine coolant, transmission oil, hydraulic oil and air inlet manifold are constantly monitored to adjust the speed of the fan to cooling requirements. Controlled fan speed improves fuel efficiency.

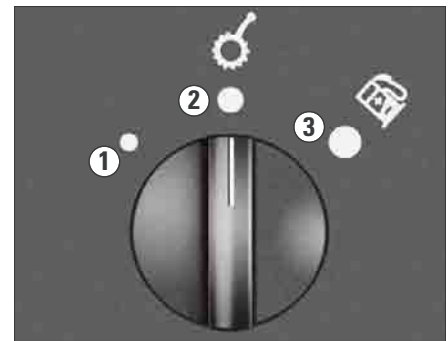

Fuel Efficiency

With the 980H, horsepower and shift points can be tailored to match application requirements in turn improving fuel economy. Caterpillar allows operators to choose between two horsepower settings through the Variable Shift Control (VSC) dial. When the dial is positioned in the Standard Mode (1), operators will realize **354** constant net horsepower and shifts occurring at higher engine rpm's. In the Intermediate Mode (2) operators will experience **322** constant net horsepower and transmission shifting at lower rpm's. Using the Economy Mode (3) engine rpm's at which shifting occurs will be further reduced while constant net horsepower remains at **322**.



Maintenance. Proper maintenance of your wheel loader can help control expenses and lower your owning and operating costs. The 980H provides unmatched serviceability.

- Well-protected, easily visible sight gauges
- Ground level maintenance points
- Easy access to engine compartment
- Ecology drains for simple and clean fluid drainage
- Brake wear indicators for ease of inspection
- Airborne debris-resistant, swing-out grill provides more efficient airflow

S•O•S Services. Managing component life and machine availability decreases downtime while improving your productivity and efficiency. S•O•S Services can help you do that. Regular fluid sampling is used to track what is going on inside the equipment. Wear-related problems are predictable and easily and quickly repairable. Maintenance can be done according to your schedule, resulting in increased uptime and flexibility in maintenance and repair before failure.

Product Link. With Product Link owners can collect and track multiple types of information – from machine location and service meter hours, to health and productivity information.

EquipmentManager. With a subscription to EquipmentManager information from Product Link can be transmitted to a computer. Return on equipment investment is optimized through maintenance management and improved uptime.



Customer Support Agreements.

A Customer Support Agreement (CSA) is any arrangement between you and your Cat dealer that helps you lower your total cost per unit of production. CSAs are flexible, allowing them to be tailored to your business. They can range from simple Preventive Maintenance Kits to sophisticated Total Cost Performance Guarantees. Having a CSA with your Cat dealer allows you more time to do what you do best – run your business.



Parts Availability. Caterpillar provides an unsurpassed level of personalized service for your wheel loader. With parts distribution centers worldwide, most parts can be delivered in 24 hours. Easy access to parts reduces downtime.

Machine Security System. Stolen equipment equates to lost production and increased costs. Eliminate machine theft and unauthorized usage with the Cat Machine Security System (MSS). It is integrated into the machine's electronic system and can protect most brands of equipment by requiring a uniquely coded key to start the machine.

Caterpillar Equipment Training Solutions.

A thorough understanding of machine systems and a high level of skill in operation helps achieve maximum efficiency and improves return on investment. Caterpillar Equipment Training Solutions programs help provide operators with high levels of proficiency and confidence. Contact your Cat Dealer for more information on Caterpillar Equipment Training Solutions programs.

Caterpillar Financial Services Corporation.

Cat Financial understands your business, your industry and the challenges you face. That's why they can provide payment plans to fit your unique needs – and to help you achieve your goals.

Resale Value. Owning quality equipment is a very important factor in maintaining resale value. Cat not only supplies quality equipment but also provides product and dealer support to maintain the reliability and durability of your machine.

Engine

Cat C15 with ACERT Technology	
Gross Power	293 kW/398 hp
Net Power at 1800 rpm	
ISO 9249	260 kW/354 hp
80/1269/EEC	260 kW/354 hp
Peak Torque (net) at 1250 rpm	1686 Nm
Net Torque rise	22%
Bore	137 mm
Stroke	172 mm
Displacement	15.2 liter

- All engine horsepower (hp) are metric including front page.
- EU Stage IIIA compliant
- Rating for net power advertised based on power available when the engine is equipped with alternator, air cleaner, muffler and on-demand hydraulic fan drive at maximum fan speed.

Operating Specifications

Operating Weight	31 170 kg
Static Tipping Load, Full Turn	20 780 kg
Breakout Force	212 kN
Bucket Capacities	4.5 to 6.1 m ³

- Operating weight with 5.7 m³ general excavation bucket and bolt-on cutting edge.

Axles

Front	Fixed
Rear	Oscillating ± 13°
Maximum Single-Wheel Rise and Fall	550 mm

Sound

- The operator sound pressure level measured according to the procedures specified in ISO 6396:1998 is 75 dB(A) for the cab offered by Caterpillar, when properly installed, maintained and tested with the doors and windows closed.
- Hearing protection may be needed when operating with an open operator station and cab (when not properly maintained or doors/windows open) for extended periods or in noisy environments.
- The European Union 2005/88/EC labeled spectator sound power level is 108 dB(A).

Hydraulic System

Implement System	
Pump Output	464 l/min
Relief lift and tilt valve setting	207 bar
Hydraulic Cycle Times	
Raise	6 seconds
Dump	2
Lower, Empty, Float Down	3
Total	11

- Implement system, gear-type pump (rated at 2100 rpm and 69 bar)
- Cycle times with rated payload

Service Refill Capacities

	Liters
Fuel Tank	479
Cooling System	83
Crankcase	34
Transmission	62
Differentials and Final Drives	
Front	87
Rear	87
Hydraulic System (including tank)	250
Hydraulic Tank	125

ROPS/FOPS

- Caterpillar cab with integrated Rollover Protective Structure (ROPS) is standard in Europe.
- Rollover Protective Structure ROPS meets ISO 3471:1994 criteria.
- Falling Objects Protective Structure (FOPS) meets ISO 3449:1992 Level II criteria.

Brakes

Meet ISO 3450:1996 standard.

Transmission

Forward	km/h
1	7
2	12
3	21
4	36
Reverse	
1	8
2	14
3	24
4	41

- Maximum travel speeds (29.5–25 tires)

Tires

29.5 R 25, L-3 (XHA)
 29.5 R 25, L-5 (XLDD2A)
 29.5 R 25, L-5 (XMINED2)
 29.5 R 25, L-3 (VMT BS)
 29.5 R 25, L-4 (GB4B)

In certain applications (such as load and carry) the loader's productive capabilities might exceed the tires' tonnes-km/h capabilities. Caterpillar recommends that you consult a tire supplier to evaluate all conditions before selecting a tire model.

Dimensions

All dimensions are approximate

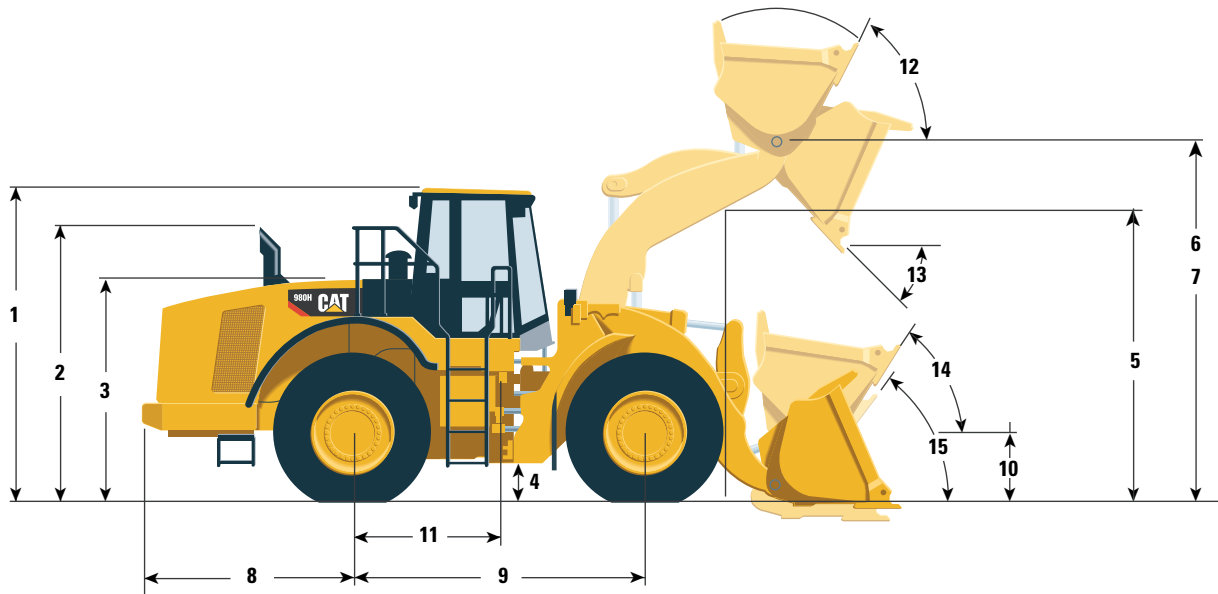

	mm	
1	Height to top of ROPS	3765
2	Height to top of exhaust pipe	3716
3	Height to top of hood	2716
4	Ground clearance with 29.5 R 25, L-3	442
5	Lift arm clearance and maximum lift	3764
6	Bucket hinge pin height (B-pin)	4505
7	Optional lift height	4726
8	Center line of rear axle to edge of counterweight	2493
9	Wheelbase	3700
10	Bucket hinge pin height at carry (B-pin)	867
11	Center line of rear axle to hitch	1850
12	Rack back at maximum lift	61°
13	Dump angle at maximum lift	47°
14	Rack back at carry	49°
15	Rack back at ground	41°

Tire Specifications

	Width over tires	Ground clearance	Change in vertical dimensions	Change in operating weight	Change in static tipping load
	mm	mm	mm	kg	kg
29.5 R 25, (L-3 STL2+), Continental	3264	452	10	71	509
29.5 R 25, (L-3 STL3), Continental	3264	450	8	-16	441
29.5 R 25, (L-3 VMT), Bridgestone	3211	469	27	93	-43
29.5 R 25, (L-3 VSDL), Bridgestone	3202	479	37	1311	1245
29.5 R 25, (L-2/L-3 GP2B), Goodyear	3269	463	21	-91	129
29.5-25, (L-3 RT3B), Goodyear	3253	444	2	-297	-206
29.5-25, (L-4 GP4B), Goodyear	3284	483	41	330	411
29.5-25, (L-5 RL5K), Goodyear	3266	488	46	942	943
29.5 R 25, (L-3 XHA), Michelin	3227	442	0	0	0
29.5 R 25, (L-5 XLDD), Michelin	3212	458	16	836	587
29.5 R 25, (L-5 XMINED2), Michelin	3231	467	25	1318	1058

Operation Specifications

		Universal Buckets				General Excavation Buckets			
		Bolt-on Cutting Edge	Flush-Mounted Teeth	Bolt-on Cutting Edge	Flush-Mounted Teeth	Bolt-on Cutting Edge	Tips and Segments	Bolt-on Cutting Edge	Tips and Segments
Rated bucket capacity	m ³	6.1*	6.1*	5.6	5.6	6.1*	6.1*	5.7	5.7
Struck capacity	m ³	5.3	5.3	4.9	4.9	5.2	5.2	4.9	4.9
Width	mm	3602	3580	3602	3580	3447	3533	3447	3533
Dump clearance at full lift and 45° discharge ⁴	mm	3131	2909	3184	2961	3222	3059	3266	3108
Reach at full lift and 45° discharge ⁴	mm	1404	1664	1350	1611	1597	1732	1537	1678
Reach with lift arms horizontal and bucket level ⁴	mm	3032	3373	2957	3299	3086	3295	3013	3223
Digging depth	mm	193	153	193	153	141	141	141	141
Overall length ⁴	mm	9531	9852	9456	9778	9543	9781	9470	9702
Overall height with bucket at full raise	mm	6355	6355	6272	6272	6435	6435	6343	6344
Loader turning radius with bucket in carry position	mm	8012	8083	7993	8063	7934	8044	7915	8021
Static tipping load straight ¹	kg	20940	21102	21127	21288	22755	22724	23184	22966
Static tipping load at full articulation (37°) ¹	kg	18790	18948	18969	19128	20360	20323	20778	20575
Breakout force ²	kN	204	205	215	216	199	198	212	211
Bucket weight	kg	3401	3300	3296	3190	2981	3072	2828	2902
Operating weight ¹	kg	31348	31247	31243	31137	31324	31415	31171	31245

* For Aggregate Arrangements

¹ Static tipping load and operating weight shown are based on average machine configuration with sound suppression cab and ROPS, secondary steering, air conditioning, ride control, limited slip rear, roading fenders, autolube, front access platform, back-up alarm, 29.5 R 25, L-3, tires for Universal buckets, L-4 tires for General Excavation buckets, L-5 tires for Rock buckets, full fuel tank, coolant, lubricants, lights, directional signals, CE plates and operator.

² For buckets with adapters, tips and segments, value is measured 100 mm behind the tip of the segment, with bucket hinge pin as pivot point, in accordance with SAE J732C.

³ All buckets shown can be used on the high lift arrangement. High lift column shows changes in specifications from standard lift to high lift. Add or subtract as indicated to or from specifications given for appropriate bucket to calculate high lift specifications.

Dimensions for dump clearance, reach and overall length:

⁴ Actual dimensions taken at the tip of the Ground Engaging Tools, either the tip of the bolt-on cutting edge or the tip of the teeth, general duty.

							Rock Buckets				High Lift ³
						V-Edge		Serrated V-Edge			
Bolt-on Cutting Edge	Tips and Segments	Bolt-on Cutting Edge	Tips and Segments	Bolt-on Cutting Edge	Tips and Segments	Tips and Segments		Integrated Teeth			
5.4	5.4	5	5	4.6	4.6	5.1	4.5	5.1	4.5	same	
4.5	4.5	4.2	4.2	3.9	3.9	4.3	3.7	4.3	3.7	same	
3447	3533	3447	3533	3447	3533	3504	3504	3492	3645	same	
3306	3149	3369	3213	3442	3289	3038	3208	3103	3180	+221	
1508	1650	1460	1604	1410	1557	1903	1773	1912	1752	+2	
2963	3173	2883	3093	2793	3003	3445	3239	3413	3237	+159	
141	141	141	141	141	141	150	100	114	68	+99	
9420	9652	9340	9572	9250	9482	9948	9696	9871	9729	+201	
6271	6271	6201	6201	6125	6125	6290	6408	6290	6399	+221	
7902	8008	7881	7987	7859	7963	8153	8010	8123	8021	+72	
23142	23113	23364	23336	23621	23593	22272	23701	22940	23942	-1774	
20747	20714	20957	20925	21200	21168	19806	21177	20474	21418	-1620	
220	219	234	233	252	250	177	206	163	181	same	
2757	2830	2667	2741	2570	2643	3795	3084	3285	2907	same	
31100	31173	31010	31084	30913	30986	33310	32599	32800	32422	+129	

Bucket Selection Guide

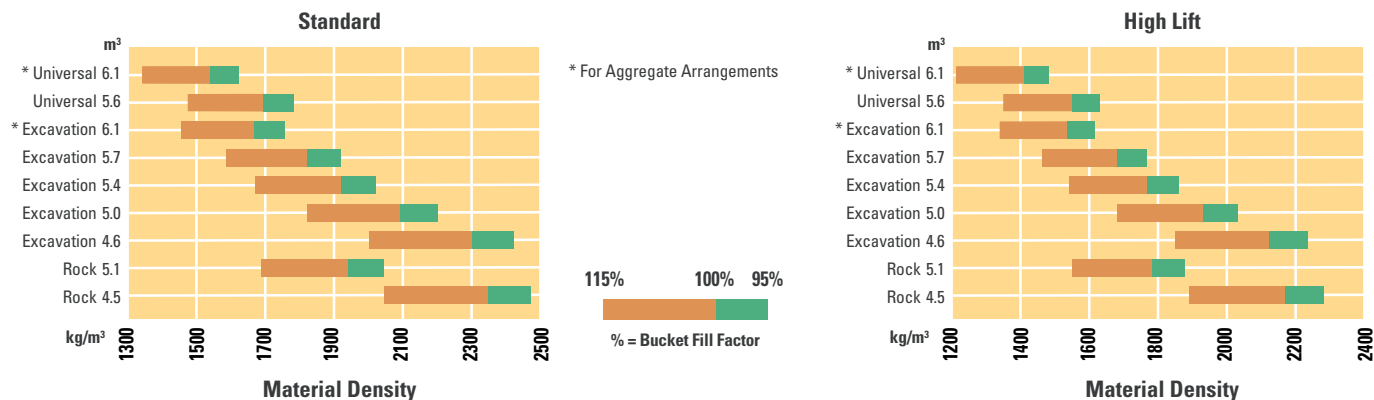

In accordance with SAE J818, these data consider the bucket load to be equal to half of the static tipping load at full turn.

Standard Equipment

Standard equipment may vary. Consult your Caterpillar dealer for specifics.

Electrical

- Alternator (80 A, brushless)
- Batteries, maintenance-free (4)
 - 1000 CCA
- Lighting system, halogen (6 total)
- Main disconnect switch
- Starter, electric, heavy-duty
- Starting and charging system (24 V)
- Starting receptacle for emergency start

Operator Environment

- Bucket/Work Tool function lockout
- Cab, pressurized and sound suppressed
 - ROPS/FOPS, radio ready
 - (entertainment) includes antenna, speakers, converter (12 V, 10 A) and power port
- Cigar lighter and ashtray
- Coat hooks (2) with straps
- Command Control Steering
- Computerized Monitoring System
- Controls, bucket/work tool
 - electro-hydraulic
- Heater and defroster
- Horns, electric
- Instrumentation, Gauges:
 - Digital gear range indicator
 - Engine coolant temperature
 - Fuel level
 - Hydraulic oil temperature
 - Speedometer/Tachometer
 - Transmission oil temperature
- Instrumentation, Warning Indicators:
 - Axle oil temperature
 - Electrical, alternator output
 - Engine air filter restriction
 - Engine oil pressure
 - Fuel level and pressure
 - Hydraulic oil filter bypass
 - Hydraulic oil level
 - Parking brake
 - Service brake oil pressure
 - Primary steering oil pressure
 - Transmission oil filter bypass

- Intermittent front wiper
- Lunchbox and beverage holders
- Mirrors, rearview (externally mounted)
- Seat, Cat Comfort (cloth) air suspension
- Seatbelt, retractable
- Steering column, adjustable, tilt and telescope
- Wet-arm, wipers/washers
 - (front and rear)
- Window, sliding left sid

Power Train

- Brakes, full hydraulic enclosed wet-disc with Integrated Braking System (IBS) and brake wear indicator pin
- Engine, Cat C15 with ACERT Technology and ATAAC
- Fan, radiator, hydraulically driven, variable speed (temperature sensing)
- Filters, fuel/engine air,
 - primary/secondary
- Fuel priming pump (electric)
- Fuel/water separator
- Muffler, sound suppressed
- Precleaner, engine air intake
- Radiator, modular
- Sun visor, front
- Switch, transmission neutralizer lockout
- Torque converter (free wheel stator)
- Transmission, automatic planetary
 - power shift (4F/4R)
- Variable Shift Control (VSC)

Other

- Antifreeze
 - Premixed 50% concentration of Extended Life Coolant with freeze protection to -34°C
- Automatic bucket positioner,
 - in-cab adjustable
- Counterweight
- Couplings, Caterpillar O-ring face seals
- Doors, service access (locking)
- Ecology drains for engine, transmission and hydraulics
- Fenders, steel front with mud flaps/rear
 - with extensions
- Guard, power train and crankcase
- Hitch, drawbar with pin
- Hood, non-metallic power tilting
- Hoses, Caterpillar XT™
- Hydraulic oil cooler (swing-out)
- Kickout, lift and tilt, automatic
 - (in-cab adjustable)
- Linkage, Z-bar, cast cross tube/tilt lever
- Oil sampling valves
 - Hydraulic circuits
 - Engine oil
 - Transmission oil
 - Coolant
- Product Link ready
- Remote diagnostic pressure taps
- Sight Gauges:
 - Engine coolant
 - Hydraulic oil level
 - Transmission oil level
- Steering, load sensing
- Tires, Rims and Wheels (see pg.14-15)
- Vandalism protection caplocks

Optional Equipment

Optional equipment may vary. Consult your Caterpillar dealer for specifics.

Aggregate Autodig
Air conditioner/HVAC system
Alarm, back-up
Autolube
Axle ecology drain
Axle oil cooler ready
Axle oil cooler
Buckets and work tools
Bucket Ground Engaging Tools (GET)
– see Cat dealer for details
Camera, rear vision
CB radio ready (20 A)
Cooling package, high ambient 50°C
Differentials, limited slip (front or rear)
Fast fill system, fuel
Fenders, roading
Guard, front window
Guard, front window, forestry
Guard, front window, waste
Heater, engine coolant
High lift arrangement, two- and three-
valve
Hydraulic arrangement, three-valve
Joystick control (lift/tilt)

Lights, auxiliary (4)
Lights, directional
Lights, high intensity discharge (HID)
Light, warning beacon
Machine Security System
Mirrors, heated, external
Mirrors, rearview, interior
Payload Control System
Platform, window cleaning
Precleaner, turbine
Precleaner, turbine/trash
Product Link
Radio, AM/FM WB (Cassette)
Ride Control System, two- and three-
valve
Rubber-mounted cab glass
Seat, heated
Starting aid (ether)
Steering, secondary
Special Machine Arrangements
Block Handler
Forest Machine
Steel Mill Arrangement
Window, sliding right side

Merchandising Arrangement 0 (not for EU regulated countries)

Wheel Loader
Air conditioner
Precleaner, turbine

Merchandising Arrangement 1

Wheel Loader
Conversion, CE mark
Vandalism guard
Air conditioner
Power train guard
Fast fill ready fuel system

Merchandising Arrangement 2

Wheel Loader
Conversion, CE mark
Fast fill ready fuel system
Aggregate Autodig
Deluxe seat
Ride control, 2 valve

Merchandising Arrangement 3

Wheel Loader
Conversion, CE mark
Fast fill ready fuel system
Hydraulics, 3 valve
Ride control, 2 valve

Other Special Arrangements

High Lift Arm, provides +221 mm
dump clearance
Access package (15° inclined ladder
and front access platform)

980H Wheel Loader

For more complete information on Cat products, dealer services, and industry solutions, visit us on the web at www.cat.com

Materials and specifications are subject to change without notice. Featured machines in photos may include additional equipment. See your Caterpillar dealer for available options.

© 2008 Caterpillar -- All rights reserved

CAT, CATERPILLAR, their respective logos, "Caterpillar Yellow" and the POWER EDGE trade dress as well as corporate and product identity used herein, are trademarks of Caterpillar and may not be used without permission.

HEHL3423-2 (04/2008) hr

CATERPILLAR[®]