



5 5:28PM



IR Ingersoll Rand

225

ABG

5 5:28PM



5 5:29PM





titan titan

 Imperial Brand

225

ABG

ABG[®] **Electronic Paver TITAN 225 EPM**



INGERSOLL-RAND
CONSTRUCTION & MINING

A Revolution in Paver Technology

The Titan 225 EPM (Electronic Paver Management) is equipped with the novel electronic control system for pavers.

This digital control system developed by Ingersoll-Rand ABG is based on the serial CAN-Bus system. The modular design with standard interfaces permits the system to be easily extended to cover further functions. Our EPM is a successful combination of well proven paver engineering with state-of-the-art technology resulting in higher economy and reliability on the job-site.

Advantages

- Interfaces for modern control systems and communication methods
- Straight forward operation
- Increased operational safety
- Simplified maintenance
- Lower operating costs



Specifications

Engine:	6-cylinder Deutz Diesel engine BF6M 1013, water cooled, output according to ISO 3046/1 = 100 kW (1361 HP) at 2300 1/min, fuel tank capacity 236 l				
Laydown rate (theor.):	up to 600 t/h, the actual paving output depends upon the mat thickness, the paving width and the paving speed and will vary according to the paving conditions prevailing on your job-site. Please approach us and we will be glad to calculate the actual paving output for your particular paving contract.				
Paving thickness:	up to 300 mm				
Travel drive:	2 electronically controlled hydraulic circuits, each with a variable displacement pump with proportional control and a 2-stage variable displacement motor, additionally: emergency control system.				
Speeds:	paving: 0 - 16 m/min, transport: 0 - 3.6 km/h				
Crawler unit:	robust crawler tracks with 9 tack rollers, ground contact area 2900 x 305 mm, with replaceable rubber track pads.				
Hopper:	hydraulically operated hopper wings, capacity approx. 13.5 t.				
Mix conveyor system:	conveyors and augers are individually driven, mix level paddles for conveyor control and ultrasonic sensors for auger control; height adjustable and reversible augers, central auger drive is a standard feature.				
Weights*:	with VB 76	– 5.00 m	approx. 16.6 t	– 7.00 m	approx. 17.1 t
	with VB 81	– 6.00 m	approx. 17.2 t	– 7.00 m	approx. 17.8 t
	with MB 122	– 2.50 m	approx. 14.9 t	– 7.00 m	approx. 17.6 t
	with Omni IA	– 4.00 m	approx. 15.1 t	– 5.20 m	approx. 15.3 t
	* approximate weights without extras				
Dimensions:	as per drawing, transport width 2.50 m (with VB 81 = 3.00 m)				

Pavers may be illustrated with extras - Specifications are subject to alteration

Extras

Side curtains for all-weather roof • remote data transfer system • analog or digital levelling system • levelling beam • levelling tube • 2 additional rear working lights • screed anti-climbing lock • partial neutralization of screed load • screed tensioning device • simultaneous adjustment VARIO • spacers • hydr. crown control adjustment • hydr. auger height adjustment • edging shoes 45° • central lubrication system (augers and conveyors) • emulsion spray cleaning system • heavy duty spray gun • Thermo-Control for gas blower heating on the screeds • biodegradable hydraulic oil • Diesel transfer pump • warning beacon • tarpaulin for the whole machine • service kit

Electronic Paver Management

- ■ ■ Interface for remote paver control
- ■ ■ Data transfer
- ■ ■ Reference wire steering
- ■ ■ Monitoring of performance data
- ■ ■ Integrated levelling system
- ■ ■ Corrective maintenance
- ■ ■ Monitoring of all major components
- ■ ■ Integrated diagnosing system with data transfer by telephone

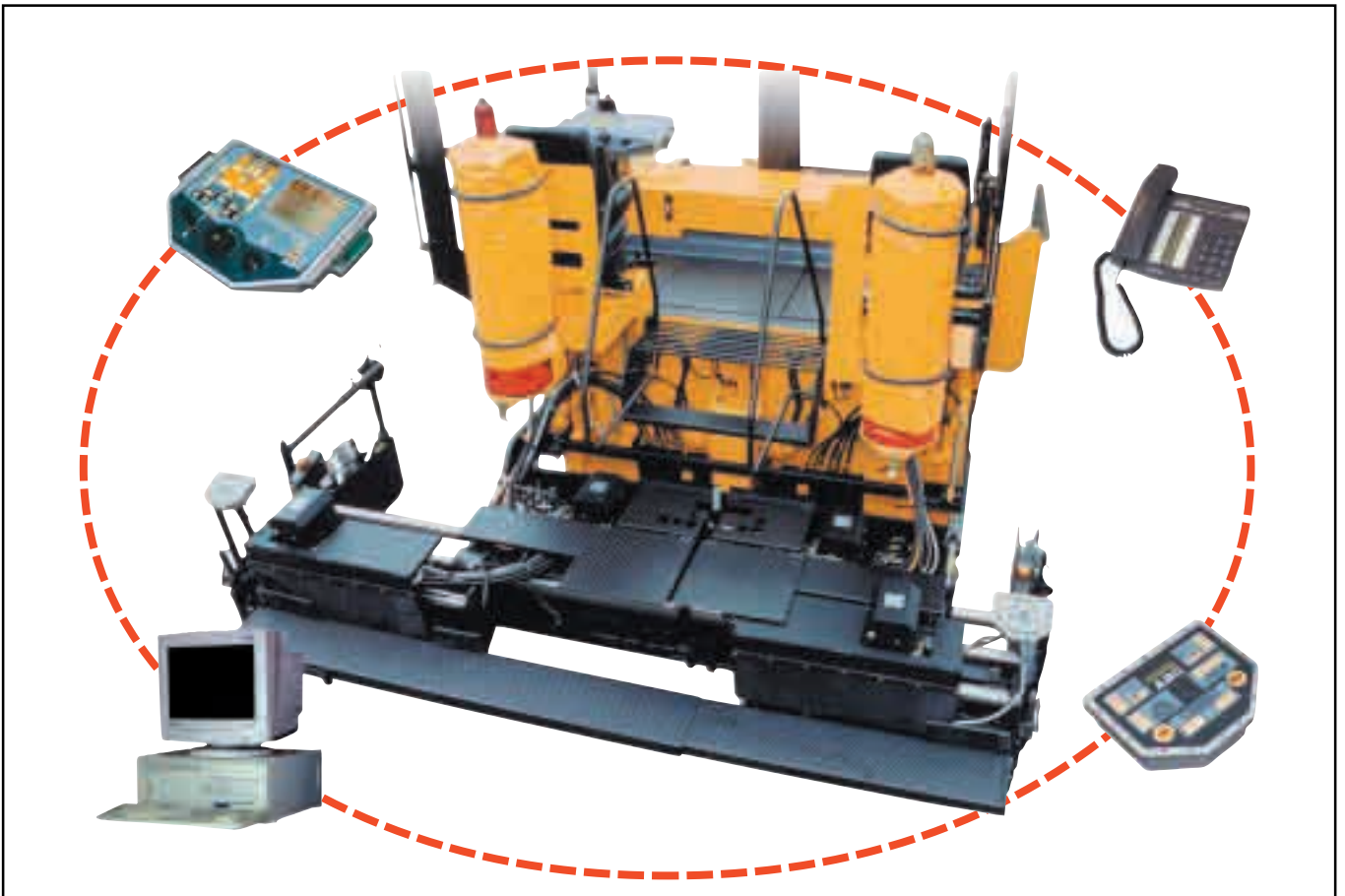

The operator's view



Trend setting operating comfort

When developing the „EPM“ one of our main objectives was to develop a paver with a straight forward and easy operation:

- Revolutionary electronic control system for the optimum support of all paving processes.
- All relevant process data is clearly indicated on a display screen integrated into the central control panel and can be recognized at a glance.
- Distinct and easy to read symbols ensure a correct and efficient paver operation.
- The control unit can be easily and quickly adjusted to the operator's individual operating position.
- Elevated and laterally extendible de luxe seats ensure an excellent all-round view.
- Seat with railings and all-weather roof can be extended beyond the paver's platform on both sides ensuring that the auger channel, hopper, outer edge of the crawler unit and direction indicator are all within the operator's field of vision.

A modern, clean and tidy working place !



Exemplary ease of maintenance

High operational safety

Our „EPM“ system incorporates components which have proven their reliability and durability in everyday operation as well as under the toughest and most adverse operating conditions:

- Constant monitoring of the paving process and the correct function of all major components,
- Control commands are transmitted to the paver by robust and interchangeable control modules.



Integrated diagnosing system

The „EPM's“ memory storage informs the maintenance crew of all machine occurrences, even though they took place some days ago, in order to easily and correctly perform routine maintenance work:

- Computer link for remote diagnosis by telephone ensures a quick and more efficient maintenance support by IR-ABG's Service Department.



Easy access to all components Low degree of maintenance



- Little effort required to swing open the engine bonnet and side covers.
- The Diesel engine and all hydraulic components are easily accessible from all sides.
- All major lube points and oil drain pipes are projected outwards for easy access.
- Central lubrication system for the bearings on the conveyors and distributor augers (option).
- Track roller bearings with lifetime lubrication.
- Emulsion cleaning system with 40 litre tank (option).
- Test points incorporated in the hydraulic circuits for pressure control.

Choice of four screeds

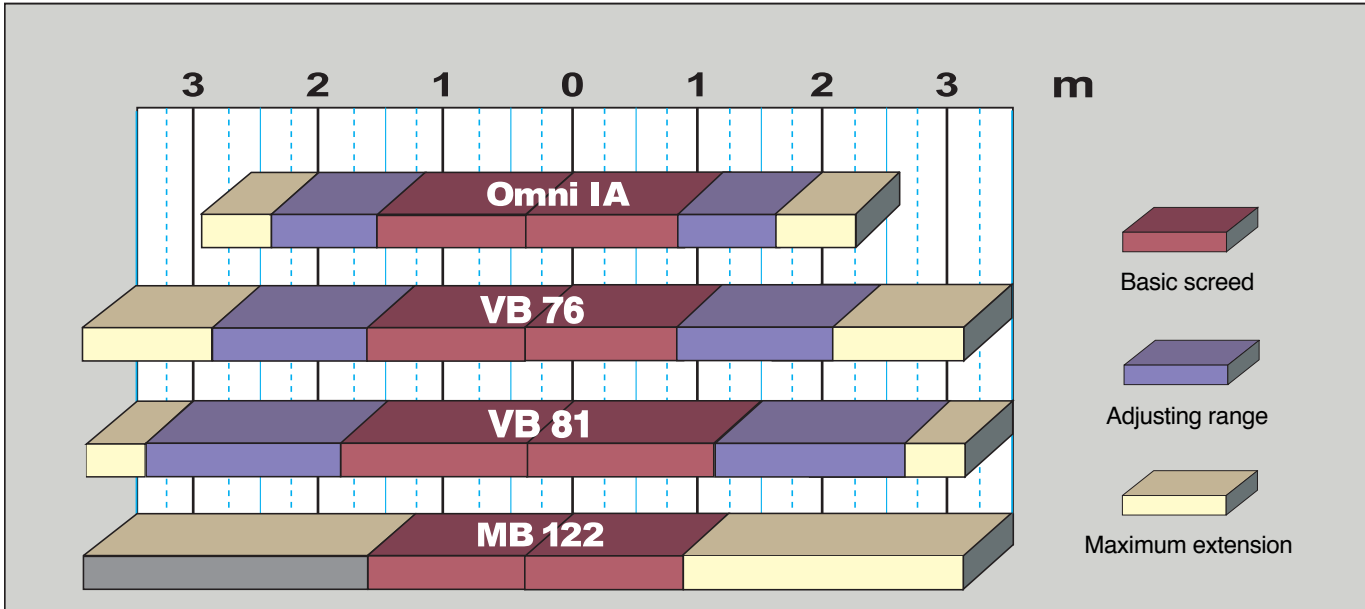

Standard Screeds

VB 76 and VB 81

Infinitely variable up to double the basic width:

- increases flexibility when changing paving widths,
- reduced assembly work.

Omni IA

Vibrating screed.

Lateral inclination on each extensible screed adjustable up to 6%.

Manually extensible screed MB 122

Alterations to the paving width in increments of 0.25 m.

Screed type	Screed extension system	Basic adjusting range/ basic width	Max. paving width with extensions	Tamper frequency	Vibration frequency
Omni screed IA	hydraulic	2,44 - 4,00 m	5,20 m	-	up to 2250 1/min
VARIOMATIC screed VB 76	hydraulic	2,50 - 5,00 m	7,00 m	up to 1650 1/min	up to 3200 1/min
VARIOMATIC screed VB 81	hydraulic	3,00 - 6,00 m	7,00 m	up to 1650 1/min	up to 3200 1/min
Standard combi screed MB 122	manual	2,50 m	7,00 m	up to 1470 1/min	up to 3700 1/min

Applications

Paving projects

- Rural roads, main roads and highways
- Urban roads
- Car parks and approaches
- Industrial areas and yards
- Landscape projects
- Road repair and maintenance work

Paving materials

Wearing, binder and base courses in paving widths up to 7.00 m:

- All kinds of bituminous materials
- Cement treated mineral mixes
- Graded aggregates
- Sand and gravel



Technical features

New generation of modern Diesel engines

Water-cooled Deutz Diesel engine BF6M 1013 with 100 kW (136 HP) output:

- low exhaust emission (already meets COM Stage 1)
- lower fuel consumption
- lower noise level

Extremely robust crawler unit with high tractive power

Rugged long crawler tracks mounted on compact welded track frames with replaceable rubber track shoes:

- the high static friction of the crawler tracks together with the paver's weight achieve a very high tractive force.

Travel drive with electronic drive control

Electronically controlled hydrostatic individual drives for each crawler track.

The digital electronic control exactly maintains the preselected speed or the preselected curve radius:

- uniform drive even at varying tractive resistances,
- exact straight line travel,
- smooth and non-jolting steering in curves at a constant speed.



Contra-rotating crawler track drives:

- for turning on the spot.

Variable displacement pumps with pressure cut-off devices:

- protect the hydraulic drives from overloads and overheating.

Hydraulic shift from paving speed to transport speed and vice versa:

- no interruption of power transmission and braking effect,
- synchronized control ensures no unintentional change of direction.

Integrated emergency control in the drive system:

- increased operating safety.

Drive diagram

1. Deutz Diesel engine
2. Drive pumps
3. Proportional control
4. Speed sensor
5. Spring loaded brake
6. Drive motors
7. Electronic drive control
8. EPM Control panel

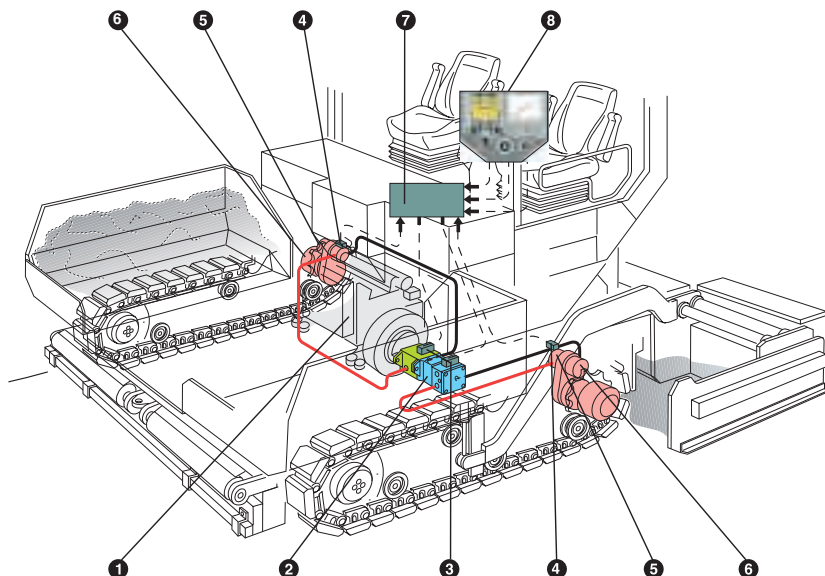

Mix conveyor system with proportional control

Large material hopper with 13.5 t capacity.

Conveyors beginning at the very front of the hopper:

- even the front of the hopper is completely emptied.



Individual hydrostatic drives for each conveyor and each distributor auger:

- mix distribution individually adapted to the requirements of each screed side.

Proportional auger speed control with ultrasonic sensors:

- uniform head of material in front of the screed,
- contact free material control.



Reversible direction of auger rotation:

- the flow of material can be directed from the left to the right and vice versa,
- uniform emptying of the hopper and dump truck,
- less shovelling work required when starting and stopping paving.

Height adjustable augers:

- easy adaption to different layer thicknesses and paving widths.



**Our Service
Phone
Numbers**

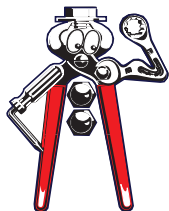

Parts Service

Phone ++49 5151/ 209 8 (group)

Phone ++49 5151/ 209 285

Fax ++49 5151/ 209 258

Customer Service

Phone ++49 5151/ 209 4 (group)

Fax ++49 5151/ 209 222

ABG

Allgemeine
Baumaschinen-Gesellschaft mbH
Kuhbrückenstraße 18
D-31785 Hameln
Tel. 05151/ 209-0
Fax 05151/ 209-204
Internet www.ir-abg.com

INGERSOLL-RAND
CONSTRUCTION & MINING

Form No. 6 · 0199/30 - CPN 56283047

