



FUTURE SERVICES

GENERAL TRADING & CONTRACTING
Tel : +965 - 2420607
Tel : +965 - 7009511
Tel : +965 - 6988075
Fax : +965 - 2420608

CAT 623E



CAT 623E

CAT 623E

623G

Wheel Tractor Scraper



Engine

Tractor Engine	Cat® C15 with ACERT® technology	
Net Power	246/272 kW	330/365 hp

Scraper Bowl

Heaped Capacity	17.5 m ³	23 yd ³
Rated Load	25 000 kg	55,115 lb

Weights

Total Operating – empty	37 435 kg	82,530 lb
-------------------------	-----------	-----------

623G Wheel Tractor Scraper

Responsible, productive earthmoving machines, built to last.

Power Train – Engine

- ✓ Electronically controlled Caterpillar® engines with ACERT technology, modular radiator with 9 fins per inch, and an Electronic Control Module maximizes power to the cutting edge and exceptional haul road speed. **pg. 4**

Power Train – Transmission

- ✓ Planetary powershift transmission delivers excellent load capability. Redesigned front and rear axles accommodate wider brake shoes and drums. The neutral coast inhibitor and programmable top gear reduce wear while increasing machine performance. **pg. 6**

Electronic Controls

- ✓ Electronic controls improve machine response and provide advanced diagnostic capabilities that result in better machine availability. The Product Link option allows remote monitoring of location, machine system status, and alert indicators. **pg. 7**

Elevator Mechanism

The elevator mechanism conditions material as it works, lifting material off the cutting edge and carrying it to the top of the load for true self-loading capability. The 623G is ideal for windrowing, blending material as well as breaking up vegetation in stripping operations. **pg. 12**

Serviceability

- ✓ The latest electronic monitoring systems, grouped service points, and rugged Caterpillar components simplify maintenance and minimize downtime. New two-piece access doors open easily and stay open for better access. **pg. 13**

Quick loading, high travel speeds and the ability to load and spread on the run yield fast cycle times, allowing Cat Elevating Scrapers to consistently deliver high productivity at the lowest cost per ton.



Operator Station

Convenient control placement and a comfortable work environment are keys to high productivity. Features include Single Lever Implement Control, an air seat suspension and improved instrumentation. **pg. 8**

Structures

Superior structural design delivers state-of-the-art ride, capacity, and material control while assuring the durability and reliability customers expect from Caterpillar. **pg. 10**

Scraper Bowl

- ✓ Caterpillar Scraper bowls deliver large loads with better retention, excellent material flow, fast cycle times and high productivity. Relocating the implement valve to the draft tube improves access and serviceability. **pg. 11**

Customer Support

The best parts availability and the best service capability will help keep your equipment working. **pg. 14**



✓ *New Feature*

Power Train – Engine

The new ACERT technology and proven components are electronically integrated to achieve new levels of performance and efficiency.



C15 Tractor Engine. The Cat C15 Electronically Controlled Unit Injection (EUI) diesel engine powers the tractor. With dual horsepower capability, it provides high power and torque rise for excellent lugging in tough loading conditions. The C15 is designed for long hours of continuous operation with high displacement and low RPM ratings.

Dual Horsepower. Electronic engines deliver increased power when the auger is engaged or when the machine is in the roading gears, providing quicker acceleration on the haul road.

ACERT Technology. The C15 electronic engine with ACERT technology meets US EPA Tier 3 and European Union Stage III exhaust emission regulations. ACERT technology reduces emissions during the combustion process by using advanced technology in the air and fuel systems, in conjunction with integrated electronics. Caterpillar meets emission regulations at the combustion source rather than recycling exhaust gases.

Electronic Control Module (ECM).

The ECM responds to operator commands and engine sensor input to optimize engine and machine performance. This advanced engine management software controls and protects the engine at all times against cold starts, high altitude operations and air filter plugging by monitoring:

- injection timing and pressure
- engine cooling fan speed
- ether starting aid
- hydraulic pumps

ADEM™. The ADEM controls engine speed by adjusting the fuel duration, resulting in quicker starts in hot and cold weather, better fuel economy, better operator response, and automatic compensation for altitude and filter plugging.

Air-to-Air Aftercooling (ATAAC).

Reduces air inlet temperature for enhanced combustion efficiency, reduced engine exhaust emissions levels, higher altitude capability, and more power.

Greater Reliability. The EUI system has fewer moving parts than mechanical unit injection and requires few adjustments. ECM communicates with the monitoring system (EMS) to warn the operator of potential problems, reducing the potential for major damage from occurring.

Maintenance. EUI engines have virtually no mechanically controlled parts to wear or adjust. These have been replaced by electronic controls, reducing maintenance costs and increasing machine availability.

Control Throttle Shifting (CTS).

Automatically synchronizes engine speed to transmission speed when shifting gears. CTS reduces power train stress and increases component life, as well as providing a smoother ride for the operator.

Automatic Ether Injection. ECM activates the ether injection system during engine cranking to help ensure reliable engine start-up in extreme cold operating conditions.

Directional Shift Management.

During directional shifts or shifts from neutral during high engine speed, engages speed clutches before directional clutches to reduce power train energy and increase power train life.

Automatic Altitude Compensation.

The Electronic Control Module automatically matches fuel delivery to barometric pressure. Auto deration protects against excessive combustion temperatures that could result in component damage.

Diagnostic Capability. Electronic Technician (Cat ET) is used to display real-time pressures, temperatures, fuel settings and diagnostic messages as well as historical information, such as engine over-speeds, overheating, low oil pressure and air filter restriction events.

Fuel Economy. Electronic controls yield a fuel savings by optimizing the timing setting for varying conditions. The ECM matches timing to the load on the engine, engine speed and temperature.

Air Filter Restriction. The ECM monitors air filter restriction and sends a warning message to the Electronic Monitoring System III to alert the operator if the restriction exceeds the allowable limit.

Reduced Exhaust Smoke. The ECM determines the optimum fuel/air ratio, then precisely controls fuel during cranking, starting and acceleration to reduce smoke. This system is faster and more efficient than mechanically controlling the governor rack position.

Low Battery Elevated Idle.

ECM automatically compensates for low alternator output at low idle by raising the rpm for brief intervals to keep the batteries fully charged.



Electronic Unit Injection (EUI).

Electronic injection provides complete control over injection timing, duration, rate and pressure under changing conditions over the entire engine operating range. The EUI controlled engine delivers:

- improved fuel efficiency
- more power
- decreased smoke and emissions
- faster hot and cold starts
- better high altitude performance
- less noise than mechanical injector engines

Engine Speed Lock. Allows the operator to maintain a given engine speed without using the accelerator pedal. This eliminates operator fatigue associated with holding the pedal down for extended periods of time. An on/off rocker switch enables the Speed Lock feature, and a dashboard lamp indicates the feature is active. Moving the rocker switch to the off position, or activating the service brakes or the retarder, disables the feature.

Automatic Belt Tensioning. Both the tractor and scraper engines now have automatic belt tensioning rather than manual tensioning. Other engine improvements include:

- reducing the number of belts (from five to two on the tractor, from four to two on the scraper)
- eliminating the servicing for fan drive bearings

Power Train – Transmission

Integrated electronics allows the machine to monitor the power train which reduces stress as well as provide a better ride to the operator.

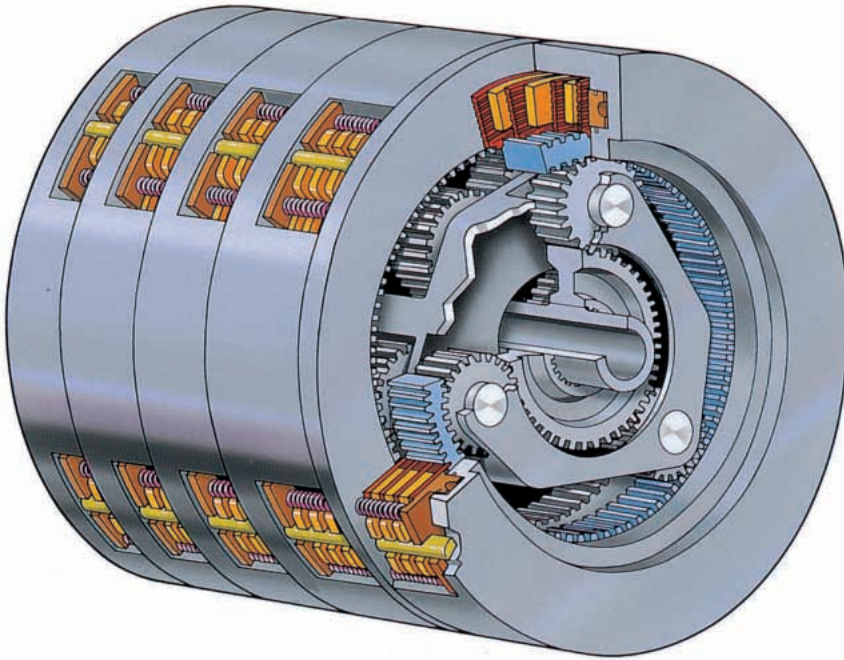

Transmission. Electronically controlled Caterpillar planetary powershift transmission with eight forward and one reverse speed. Tractor gears 1 & 2 operate in converter drive for increased torque capability during cut and fill operations. Gears 3-8 operate in direct-drive for drive train efficiency during the haul. Reverse gear operates in converter drive.

Planetary Design. Provides larger contact area between gears than countershaft transmissions for greater load-carrying capacity.

Neutral Coast Inhibitor. Neutral coast inhibitor prevents the transmission from shifting into neutral if the operator selects neutral while moving, as well as maintaining the flow of the transmission fluid.

Transmission Hold. Allows the operator to maintain converter drive for increased rimpull, or hold the current gear for enhanced control.

Programmable Top Gear Selection. Allows the operator to manually set the top gear (3rd – 8th) available to match conditions or to match the hauling speed of the fleet to specific job-site needs.

Retarder. The hydraulic retarder acts as an internal brake on the driveline that minimizes the need to apply service brakes. By engaging the retarder 3 to 4 seconds before the machine traverses a downhill grade, the operator can reduce wear on the service brakes and enhance machine control.

Differential Control. Electronic differential lock on the tractor helps prevent the drive wheels from spinning in poor underfoot conditions. The operator engages the differential lock by choosing either the right or left foot control located on the floor of the cab.

Brake Performance. Redesigned axles on both the tractor and scraper accommodate wider brake shoes and brake drums, improving brake performance as much as 20 percent and reducing brake and drum wear as much as 75 percent.

Independent Systems. Expanding shoe-type brakes are a cam-operated design that is air-applied and spring released. The braking system uses independent front and rear circuits with secondary brakes automatically applied if the service air pressure drops to 380 kPa (55 psi).

Parking Brakes. The push-button operated parking brake features a spring-applied, air-released mechanism that operates the service brakes. All brakes meet the ISO 3450: 1998 standard.

Final Drives. Outboard-mounted, planetary design final drives reduce torque loads on the other power train components. Large-capacity, double-row roller bearings and Caterpillar Duo-Cone® seals deliver exceptional reliability in the toughest applications.

Electronic Controls

Instant response optimizes machine performance, and advanced diagnostic capabilities maximize machine availability.

Simplified System. The electrical system has been redesigned to utilize three electronic control modules (ECM) on the tractor instead of four.

Air Filter Restrictor Indicator.

Electronic control module monitors air filter restriction and sends a warning message to the electronic monitoring system to alert the operator if the restriction exceeds the allowable limit.

Automatic Ether Injection. The ECM activates the ether injection system during engine cranking to enhance cold weather starting.

Automatic Altitude Compensation.

At high altitudes the system automatically de-rates fuel delivery as a function of barometric pressure sensed by the system's atmospheric pressure sensor.

Low Battery Elevated Idle. The ECM automatically compensates for low alternator output at low idle to keep the batteries fully charged.

Improved Serviceability. Combined monitoring systems, easy access diagnostics and more durable components make routine maintenance and servicing simple and fast.

Easy Access Diagnostics. Diagnostic codes are accessible through the EMS main display module, via the Electronic Technician (Cat ET). This offers a head start on problem solving, with a radio call often providing the service technician with the knowledge of which tools, troubleshooting guides, and possibly even replacement parts to bring to the machine.



Greater Reliability. The Caterpillar EUI system has fewer moving parts than mechanical unit injection and requires few adjustments. ECM communicates with the monitoring system (EMS) to warn the operator when problems arise, reducing the potential for major damage from occurring.

Maintenance. EUI engines have virtually no mechanically controlled parts to wear or adjust. These have been replaced by electronic controls, reducing maintenance costs and increasing machine availability.

Fuel Economy. Electronic controls yield a fuel savings by optimizing the timing setting for varying conditions. The ECM matches timing to the load on the engine, engine speed and temperature.

Product Link Ready. Product Link is a wireless system that allows the customer to track machine data such as location, service meter hours as well as machine health information. The system has the capability to automatically issue alerts when the machine is being operated beyond owner defined time and location limits.

Reduced Exhaust Smoke. The ECM reads electronic sensors to determine the optimum fuel/air ratio, then precisely controls fuel during cranking, starting and acceleration to reduce smoke. The ECM system is faster and more efficient than mechanically controlling the governor rack position.

Operator Station

Redesigned for enhanced operator comfort and productivity.



Multi-Adjustable Seat. The Cat Comfort Cloth Seat has an adjustable seat and armrests for maximum operator comfort.

- Swivels and locks in four positions (0°, 10°, 20° and 30°) providing the optimum operating position in the cut or on the haul.
- Fore/aft and vertical height adjustment to accommodate various sized operators.

Seat Suspension. The seat suspension redefines the ride of scrapers. It features a high performance air shock absorber with its own air compressor.

Revised Steering Column. Increases legroom a full 3.5 inches (89 mm), and reduces knee contact points.

Standard Air Conditioning. Gives the operator a comfortable workstation in various types of weather. Relocated ventilation louvers improve airflow to the operator.

Storage And Amenities. Convenient storage location includes space for a lunch box and first aid kit. The cab also has a cup holder as well as an ashtray.

Visibility. Hood and front shroud width increased to accommodate the low emission engine, the air-to-air aftercooler (ATAAC), ether starting aid, and lights. Hood corners are sloped to maintain the excellent visibility.

Single Lever Implement Control.

Simple and easy to operate, the joystick enhances the productivity of operators of all skill levels. Requires less force to control the critical scraper functions and requires less lever travel. Grab handle/hand rest next to joystick controller so operator has a place to rest hand while on the haul and return roads.

1) Bowl (forward & back)

2) Ejector (side to side)

3) Thumb rocker switch

- Apron position
- Elevator direction, speed

4) Transmission Hold

5) Cushion Hitch

6) Trigger* (not shown here – is on front of joystick)

- Auger (on/off)
- Push-Pull (bail up/down)
- Elevator (on/off, resume)

* Standard open bowl does not have a trigger

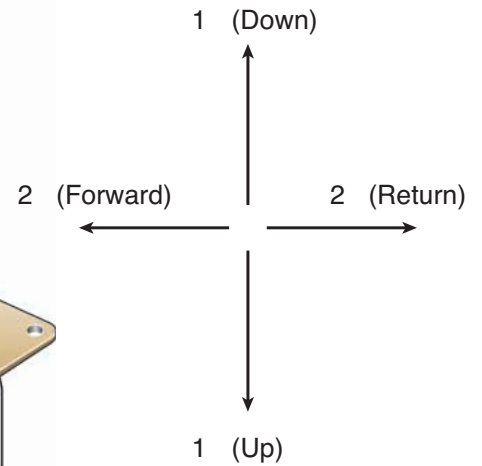
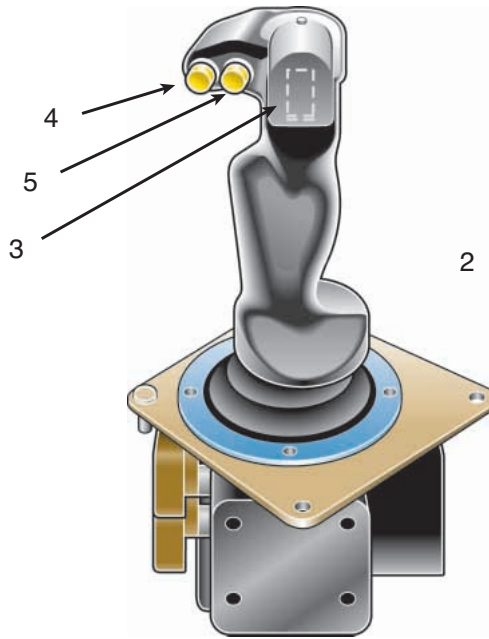

Instrument Display Panel. Features a quad-gauge layout showing engine coolant temp, transmission/torque converter oil temp, fuel level, and system air pressure.

Logical Control Placement.

Frequently used switches and indicator lights are on the instrument panel, and less frequently used switches on the overhead console.

Engine Speed Lock Controller.

Enhances operation during long haul cycles by allowing the operator to maintain a desired engine speed without maintaining pressure on the accelerator.

Simplified Transmission Control.

Simplifies gear selection (1st, 2nd, Drive and Reverse) and allows operator-defined top gear control. Relocating the gear control to the rear increases operator legroom.

Structures

Superior structural design and construction optimize performance and reliability.

- 1 Load cylinder
- 2 Hitch castings
- 3 Scraper gooseneck
- 4 Nitrogen accumulators
- 5 Orifice
- 6 Oil from tractor hydraulic system
- 7 Leveling valve
- 8 Free floating pistons

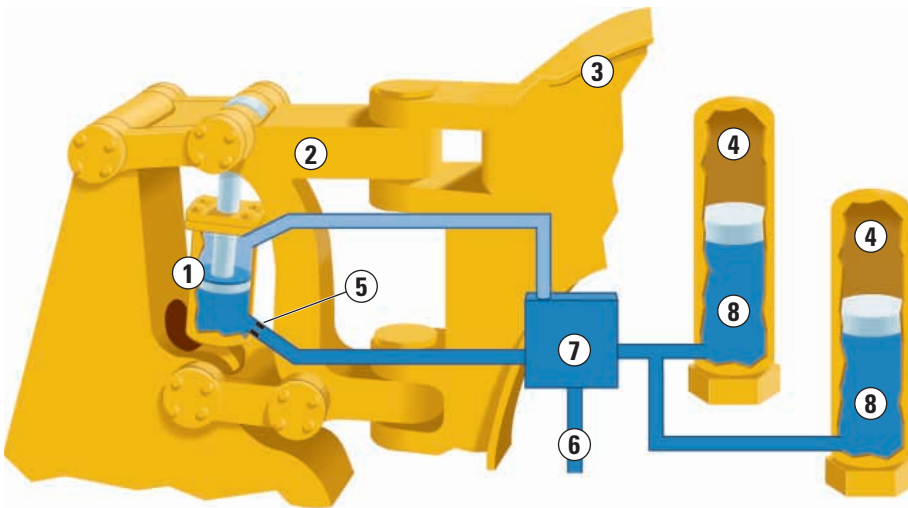

Cushion Hitch. The electronically actuated cushion hitch incorporates a parallelogram-type linkage for exceptional strength with nitrogen accumulators to deliver a smooth ride for enhanced operator comfort.

- controlled oil flow dampens rebound oscillation
- leveling valve automatically centers piston in cylinder for all loads
- steel castings are used extensively to eliminate many welded joints and increase strength
- double-kingbolt design withstands high external forces and simplifies installation and removal

Nitrogen Accumulators. Vertically mounted hydraulic cylinder transfers road shocks to nitrogen accumulators. Nitrogen accumulators absorb and dampen road shocks, thus reducing the loads from being transmitted to the operator.

Lockout Switch. An operator-selectable lockout switch, located on the joystick, locks the cushion hitch for improved control of the cutting edge during loading and dumping.

Scraper Bowl

Designed for optimum loading, material retention and ejection.



Redesigned Bowl. Excellent productivity with a 10% increase in bowl capacity from the F series, improved draft arm protection, and better load retention. Low-profile design of the bowl offers less resistance to incoming materials, while cellular construction adds strength and dent resistance to bowl sides and floor.

Bulldozer Ejection System.

Combines constant spreading control while minimizing carryback material. The floor of the bowl retracts as the ejector moves forward, allowing the operator to precisely control the flow of material.

Cutting Edges. May be adjusted according to job conditions. For most efficient loading, use the thinnest edge that provides satisfactory wear life and impact resistance.

Caterpillar Ground Engaging Tools (G.E.T.).

A wide variety of Ground Engaging Tool (GET) options, such as standard, serrated, and abrasion resistant material (ARM), are available to optimize scraper loading in various materials. Most are reversible to provide long life and reduced operating costs. Contact your Cat Dealer to learn more about the best tools for your applications.

Material Application. The 623G is ideal for windrowing, blending material as well as breaking up vegetation in stripping operations.

Elevator Mechanism

Self-loading capability, versatility and excellent material handling characteristics.

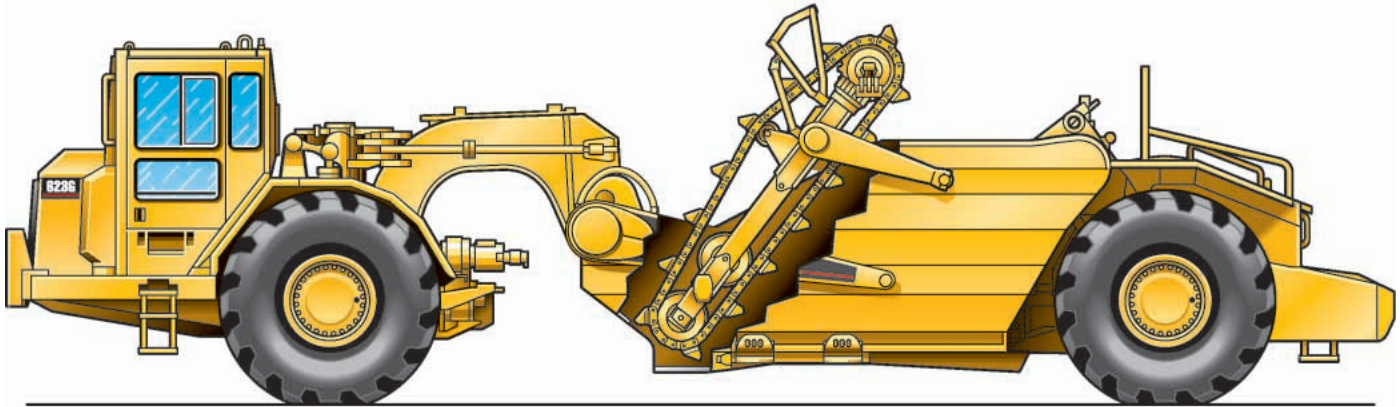

Versatility. The 623G is ideal for windrowing, blending material as well as breaking up vegetation in stripping operations.

Material Handling. The elevator lifts material off of the cutting edge and carries it to the top of the elevator and then dumps the material into the bowl. Blending the material helps eliminate voids in the bowl for consistent payloads and even unloading.

Drive Sprockets. Split, bolt-on drive sprockets eliminate the need to remove the chain during servicing and require no lubrication. Hydraulically adjustable chains have exceptional pull strength for dependable performance and long life.

Throat Opening. Adjustable up to 610 mm (24"), enables faster loading and greater material control.

Low-Maintenance Rollers. Carrier rollers and chain idlers are heat-treated for wear resistance. Fixed elevator rollers require no adjustment, reducing maintenance. Sealed and lubricated floor rollers are maintenance free. The direct acting floor mechanism eliminates the drag link.

Two-stage Ejection System. Allows the floor to slide backward while a dozer-type ejector moves forward (toward the cutting edge), cleaning the entire bowl in one motion.

Implement Pumps. High-pressure, engine-driven implement pumps enable the operator to take deeper cuts and load in a shorter distance with less elevator stall.

Elevator Controls. The operator has variable control of the elevator to match the speed of the elevator to the material conditions for increased productivity.

Reversible. The elevator reverses for spreading topsoil, unloading cohesive material, and blending windrowed material.

Single-pivot Design. The single-pivot elevator design improves the load profile which allows the machine to achieve consistent payloads.

Chain Adjustment. Maximize chain life quickly and easily with just a grease gun.

Serviceability

Count on Caterpillar for simplified service and the most productive uptime.



Grouped Service Points. Maintenance and service points for the engine are grouped on the right-hand side for easy access. They include the engine air cleaner, engine oil check and fill, fuel filters and priming, coolant level sight glass, window washer bottle, air conditioning dryer cartridge, ether starting aid canister, engine oil filter, fan drive lubrication, and sampling ports for the engine oil and coolant.

- Spin-on fluid filters for all but the main hydraulic filter
- Cab wiring harness redesigned and relocated for better serviceability

Electronic Monitoring System (EMS III). Monitors machine status and provides real-time information to the operator including warnings of problems identified by the Electronic Control Modules.

Event Log. The EMS event log records problems detected by the control system, including the time an event occurs, the number of occurrences for the event, an event identifier and problem code. The event log can be accessed using the Electronic Technician (Cat ET).

Implement Valve Relocation. The implement valve has been relocated from the tractor to the top of scraper draft tube, reducing the number of hoses and tubes that cross over the gooseneck. The move reduces potential leak points, and improves service access.

One Piece Power Block. Jumpstart receptacle and disconnect switch are integrated into a one-piece power block for better electrical integrity and serviceability. The disconnect switch, with a lockable cover, disables all power from the batteries and jumpstart functions.

Electro-Hydraulic Implement Control. Simplifies serviceability by removing the cab pilot valve and associated lines, which also improves reliability and reduces noise. The high efficiency electro-hydraulic pilot oil filter provides cleaner oil for the pilot system.

Scraper Electrical Harness. A ribbon wiring harness replaced the cable harness for improved wear and durability. Its increased flexibility oscillates with the machine, and polyurethane boots offer better protection against the elements.

Access Doors. The tractor has a standard two-piece door on the right side for better access to service points. The hood, hinged on the front and supported by spring struts, easily opens towards the front of the machine, for better access to the top of the engine.

Electronic Technician (Cat ET). The Caterpillar Electronic Technician (Cat ET) Service Tool is useful in troubleshooting existing problems or identifying potential problems by displaying:

- Real-time pressures, temperatures, fuel settings and diagnostic messages
- Historical data such as engine over-speeds, overheating, low oil pressure and air filter restriction events
- More detailed information to the service technician who can access ET via a laptop computer

Easy Access Diagnostics. Diagnostic codes are accessible through the EMS main display module, via the Cat ET. Relaying this information to the service technician can let him know which tools, troubleshooting guides, and possibly even replacement parts to bring to the machine.

Customer Support

Cat dealer services help you operate longer with lower costs.



Product Support. You will find nearly all parts at our dealer parts counter. Cat dealers use a world-wide computer network to find in-stock parts to minimize machine down time. Save money with genuine Cat Reman parts. You receive the same warranty and reliability as new products at substantial cost savings.

Machine Selection. Make detailed comparisons of the machines under consideration before purchase. Cat dealers can estimate component life, preventive maintenance cost, and the true cost of lost production.

Purchase. Look past initial price. Consider the financing options available as well as day-to-day operating costs. Look at dealer services that can be included in the cost of the machine to yield lower equipment owning and operating costs over the long run.

Customer Support Agreements.

Cat dealers offer a variety of product support agreements, and work with customers to develop a plan that best meets specific needs. These plans can cover the entire machine, including attachments, to help protect the customer's investment.

Operation. Improving operating techniques can boost your profits. Your Cat dealer has videotapes, literature and other ideas to help you increase productivity, and Caterpillar offers certified operator training classes to help maximize the return on your machine investment.

Maintenance Services. Talk to your dealer about the range of available maintenance services. Repair option programs guarantee the cost of repairs up front. Diagnostic programs such as S·O·SSM Analysis and Coolant Sampling and Technical Analysis help avoid unscheduled repairs.

Replacement. Repair, rebuild or replace? Your Cat dealer can help you evaluate the cost involved so you can make the right choice.

Engine

Tractor Engine	Cat C15 with ACERT technology	
Net Power – Gears 1-2	246 kW	330 hp
Net Power – Gears 3-8	272 kW	365 hp
Gross Power – Gears 1-2	268 kW	359 hp
Gross Power – Gears 3-8	294 kW	394 hp
Bore	140 mm	5.5 in
Stroke	165 mm	6.5 in
Displacement	15.2 L	928 in ³
Flywheel Power	246 kW	330 hp

- Net power advertised is the power available at rated speed of 1,800 rpm, measured at the flywheel when the engine is equipped with fan, air cleaner, muffler and alternator.

Transmission

1 Forward	5 kph	3.1 mph
2 Forward	7.6 kph	4.7 mph
3 Forward	10.9 kph	6.8 mph
4 Forward	14.8 kph	9.2 mph
5 Forward	19.9 kph	12.4 mph
6 Forward	26.9 kph	16.7 mph
7 Forward	36.4 kph	22.6 mph
8 Forward	51.5 kph	32 mph
Reverse	9.2 kph	5.7 mph

Hydraulics

Bowl Cylinder Bore	152 mm	6 in
Bowl Cylinder Stroke	508 mm	20 in
Floor Cylinder Bore	152 mm	6 in
Floor Cylinder Stroke	1353 mm	53.25 in
Ejector Cylinder Bore	127 mm	5 in
Ejector Cylinder Stroke	1220 mm	48 in
Steering Circuit	209 L/min	55 gal/min
Scraper Circuit	241 L/min	63.7 gal/min
Cushion Hitch Circuit	37 L/min	9.8 gal/min
Supplemental Steering Circuit	150 L/min	39.9 gal/min
Relief Valve – Steering Circuit	15 500 kPa	2,250 psi
Relief Valve – Implement Circuit	17 300 kPa	2,510 psi
Compensator Settings – Cushion Hitch Circuit	16 000 kPa	2,175 psi
Compensator Settings – Elevator Circuit	36 175 kPa	5,246 psi

- Steering circuit at 1,900 rpm.

Scraper Bowl

Heaped Capacity	17.5 m ³	23 yd ³
Rated Load	25 000 kg	55,115 lb
Struck Capacity	13.8 m ³	18 yd ³
Depth of Cut – Max	330 mm	13 in
Width of Cut, to Router Bits	3505 mm	138 ft
Ground Clearance – Max	387 mm	15.2 in
Cutting Edge Thickness	29 mm	1.14 in
Hydraulic Penetration Force	150 kN	33,750 lb
Depth of Spread – Max	380 mm	15 in

Elevator

Length – Overall	3730 mm	146.9 in
Width of Flight Face	217 mm	8.5 in
Length of Flights	2260 mm	89 in
Spacing of Flights	510 mm	20 in
Number of Flights	15	

Steering

Width – 180° Turn	10.9 m	35.9 ft
Steering Angle – Right	90°	
Steering Angle – Left	85°	
Hydraulic Output	209 L/min	55 gal/min

- Optional supplemental steering system meets SAE J1511 (OCT 90) and ISO 5010 (1992) requirements.

Service Refill Capacities

Fuel Tank	606 L	160 gal
Crankcase	36 L	9.5 gal
Transmission	72 L	19 gal
Differential	144 L	38 gal
Final Drive (each side)	19 L	5 gal
Wheel Coolant (each)	45 L	12 gal
Cooling System	107 L	28 gal
Hydraulic Reservoir	140 L	37 gal

Weights

Total Operating – Empty	37 435 kg	82,530 lb
Front Axle	23 958 kg	52,819 lb
Rear Axle	13 477 kg	29,711 lb
Total Shipping	36 830 kg	81,196 lb
Tractor Shipping	23 940 kg	52,778 lb
Scraper Shipping	12 891 kg	28,419 lb
Total Operating – Loaded	62 435 kg	137,646 lb
Front Axle Weight – Loaded	31 218 kg	68,823 lb
Rear Axle Weight – Loaded	31 218 kg	68,823 lb

Standards

- Rollover Protective Structure (ROPS) meets SAE J320a, SAE J1040 MAY 94, ISO 3471-1986 and ISO 3471-1994
- Falling Object Protective Structure (FOPS) meets SAE J231 JAN 81 and ISO 3449-1992
- The operator sound exposure Leq (equivalent sound pressure level) measured according to the work cycle procedures specified in ANSI/SAE J1166 OCT98 is 81 dB(A), for cab offered by Caterpillar, when properly installed and maintained and tested with the doors and windows closed.
- Hearing protection may be needed when operating with an open operator station and cab (when not properly maintained or doors/windows open) for extended periods or in noisy environments.

Dimensions

All dimensions are approximate.



623G

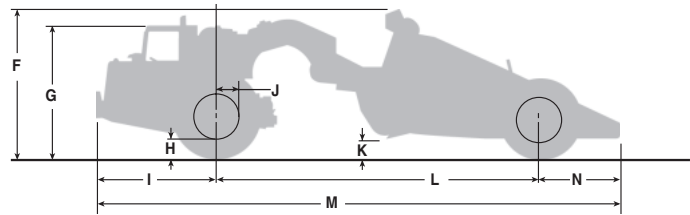

1	Width – Overall Machine	3556 mm	140 in
2	Width – Tractor	3130 mm	123.2 in
3	Width – Rear Tire Center Lines	2180 mm	85.8 in
4	Width – Inside of bowl	2946 mm	116 in
5	Width – Outside Rear Tires	3048 mm	120 in
6	Height – Overall Shipping	3708 mm	146 in
7	Height – Top of Cab	3423 mm	134.8 in

8	Ground Clearance, Tractor	553 mm	21.8 in
9	Front of Tractor to Front Axle	3058 mm	120.4 in
10	Rim Radius	432 mm	17 in
11	Height – Scraper Blade Max.	380 mm	15 in
12	Wheelbase	7976 mm	314 in
13	Length – Overall Machine	13 209 mm	520 in
14	Rear Axle to Rear of Machine	2176 mm	85.7 in

Gradeability/Speed/Rimpull

To determine gradeability performance: Read from gross weight down to the percent of total resistance. Total resistance equals actual percent grade plus 1% for each 9 kg/t (20 lb/ton) of rolling resistance. From this weight-resistance point, read horizontally to the curve with the highest obtainable gear, then down to maximum speed. Usable rimpull will depend upon traction available and weight on drive wheels.

**623G Tier 3 — Rimpull
Standard Arrangement*
Gross Weight**

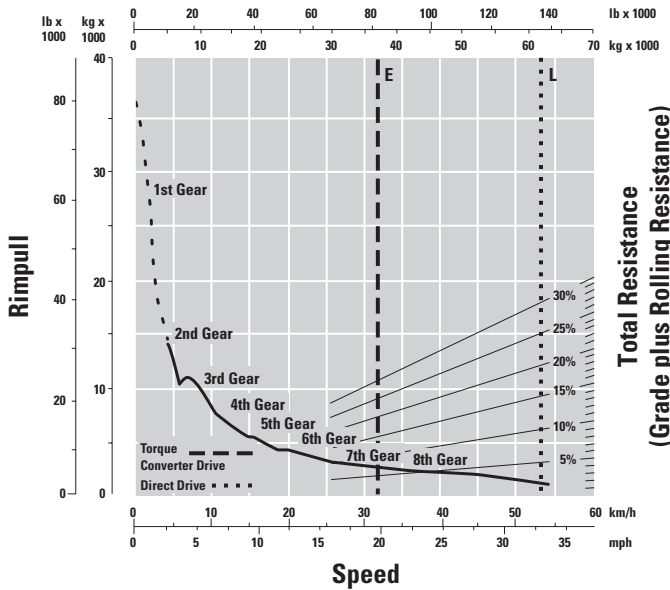

- 1—1st Gear Torque Converter Drive
- 2—2nd Gear Direct Drive
- 3—3rd Gear Direct Drive
- 4—4th Gear Direct Drive
- 5—5th Gear Direct Drive
- 6—6th Gear Direct Drive
- 7—7th Gear Direct Drive
- 8—8th Gear Direct Drive

- E—Empty 36 830 kg (81,196 lb)
- L—Loaded 62 135 kg (137,646 lb)

* at sea level

Retarding

To determine retarding performance: Read from gross weight down to the percent effective grade. (Effective grade equals actual percent grade minus 1% for each 9 kg/t (20 lb/ton) of rolling resistance). From this weight-effective grade point, read horizontally to the curve with the highest obtainable speed range, then down to maximum descent speed the retarder can properly handle.

**623G Tier 3 — Retarding*
Gross Weight**

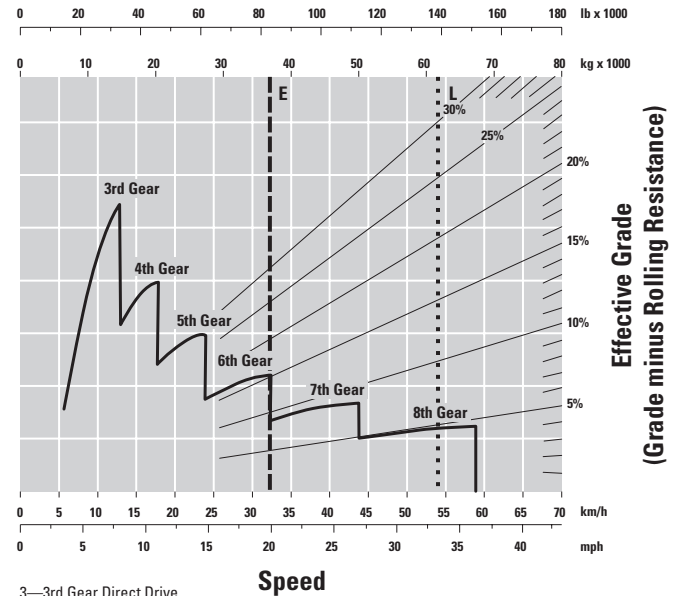

- 3—3rd Gear Direct Drive
- 4—4th Gear Direct Drive
- 5—5th Gear Direct Drive
- 6—6th Gear Direct Drive
- 7—7th Gear Direct Drive
- 8—8th Gear Direct Drive

- E—Empty 36 830 kg (81,196 lb)
- L—Loaded 62 135 kg (137,646 lb)

* at sea level

Standard Equipment

Standard equipment may vary. Consult your Caterpillar dealer for details.

ELECTRICAL

- Alarm, backup
- Alternator, 75 amp
- Batteries (4), 12V Maintenance Free, High Output
- Electrical System, 24V
- Lighting System
 - Directional Signals
 - Hazard Lights
 - Headlights, halogen with dimmer
 - Floodlight, cutting edge
 - Lighting System – Scraper
 - Directional Signals
 - Hazard Lights
 - Stop/Tail
- Starting Receptacle

OPERATOR ENVIRONMENT

- Air Conditioner (includes heater and defroster)
- Cigarette Lighter and Ashtray
- Coat Hook
- Diagnostic Connection Port (12V)
- Dome Courtesy Light
- Gauge Group
 - Air Pressure
 - Converter/Retarder Temperature
 - Electronic Monitoring System (EMS III)
 - Engine Coolant Temperature
 - Actual Transmission Gear Indicator
 - Fuel
 - Speedometer
 - Tachometer
 - Transmission Gear Indicator
- Horn
- Implement Control Joystick
- Rearview Mirrors
- Radio Ready (two radio openings, speakers, and 5-amp converter)
- ROPS Cab with Sound Suppression and Pressurization
- Static Seatbelt
- Seat, Air Suspension, Caterpillar Comfort, cloth
- Steering Wheel – tilt and telescoping
- Storage Compartment
- Engine Speed Control Lock
- Transmission Hold
- Windows – sliding side, swing out
- Windshield – laminated glass
- Windshield Wiper/Washer – front and rear

POWER TRAIN

- Engine
 - Electronic Unit Injection (EUI)
 - Electric Start, 24V
 - Fan, suction
 - Ground Level Engine Shutdown
 - Muffler
 - Starting Aid, ether
 - Thermo-shield, laminated
 - Cat C15, 6-cylinder Diesel with ACERT technology
 - Air Cleaner, dry-type with pre-cleaner
 - Radiator, NGMR (9 fins per inch)
 - Guard, crankcase
- Braking System
 - Parking/Primary/Secondary
 - Shields – brake
- Transmission
 - 8-speed Automatic Powershift with Electronic Control
 - Control Throttle Shifting
 - Differential – lockup
 - Downshift Inhibitor
 - Neutral Coast Inhibitor
 - Programmable Top-gear Selection

OTHER STANDARD EQUIPMENT

- Air Dryer
- Cushion Hitch
- Extended Life Coolant, -36°C (-33°F)
- Fast Oil Change
- Fenders
- Locks, vandalism protection
- Product Link ready
- Rims – 29 in (736.6 mm)
- Tires, 33.25-R29 radial
- Tow Pins – front and rear

Optional Equipment

Optional equipment may vary. Consult your Caterpillar dealer for details.

	<u>kg</u>	<u>lb</u>		<u>kg</u>	<u>lb</u>
Fenders, scraper	121	266	Retarder, hydraulic	150	330
Fuel System, fast-fill	10	23	Ripper Teeth	290	640
Heater, engine coolant	2	4	Steering, secondary	50	110
Lights, side vision	5	10			

623G Wheel Tractor Scraper

AEHQ5614 (12-04)

Replaces AEHQ5530 (10-00)

For more complete information on Cat products, dealer services,
and industry solutions, visit us on the web at www.cat.com

© 2004 Caterpillar
All Rights Reserved
Printed in U.S.A.

Materials and specifications are subject to change without notice.
Featured machines in photos may include additional equipment.
See your Caterpillar dealer for available options.

CATERPILLAR[®]